

# 962G

Series II  
Wheel Loader



---

Cat® 3126B ATAAC diesel engine

---

Flywheel power 152 kW/204 hp

---

Maximum flywheel power 157 kW/210 hp

---

Bucket capacities 2.9 to 4.3 m<sup>3</sup>

---

Operating weight 19 000 to 19 500 kg

# 962G Series II Wheel Loader

*State-of-the-art design, engine performance and operator comfort maximize productivity.*

---

## Engine

- ✓ *Cat 3126B ATAAC diesel engine* is built for performance, durability, excellent fuel economy, low sound levels and it meets the European Union emission regulations through 2005. This innovative engine features Caterpillar's exclusive Advanced Diesel Engine Management 2000 (ADEM-III) electronic control module for advanced troubleshooting and diagnostic capabilities. *Temperature sensing on-demand fan* slows fan speed when temperatures are low – providing a constant net power and improving fuel efficiency. **pg. 4**

---

## Electronic Transmission

- Planetary power shift transmission with automatic shift capability helps provide on-the-go speed and direction changes. The Electronic Clutch Pressure Control (ECPC) allow for smoother shifts and transmission neutralization, which let the operator adjust for specific site conditions. *Variable Shift Control* allows the operator to match the shift pattern to the application, improving operator comfort and fuel efficiency.
- ✓ *The Integrated Braking System* integrates a downshifting and neutralizer logic into the left-hand brake pedal. *Free Wheel Stator torque converter* increases efficiency thus lowered oil temperatures and improved fuel economy. **pg.5**

---

## Axles

- Large diameter axle shafts on the high torque side of the final drive provide greater torsional strength. Axle oil temperature sensors are standard. **pg. 6**

---

## Frame

- Durable, articulated frame has a full box-section which absorbs twisting and impact forces to provide a solid foundation for the entire structure. Superior engineering and materials provide excellent strength and durability. **pg. 7**

---

## Hydraulics and Operator Controls

- Enhanced, low-effort operator controls for steering, shifting and bucket loading precisely respond to operator input. Operator controls can be configured two ways – with Command Control steering and electro-hydraulic implement controls, or with Conventional steering and pilot hydraulic implement controls. **pg. 8-9**

---

## Operator Station

- ✓ *Redesigned cab* provides improved operator comfort with new Caterpillar air suspension seat. *Enhanced dash panel* layout with upper right panel provides ergonomically positioned gauge indicators and switches. *Wider front windshield* with a larger wiper sweep for a cleaner window resulting in better visibility. **pg. 10-12**

## ***Performance and comfort you can feel.***

*Caterpillar® design delivers excellent breakout force, fast load and cycle times, precise maneuvering and smoother shifts for optimal performance and comfort.*

## ***Reliability you can trust.***

*Proven components, field-tested durability, combined with easy maintenance, ensures reliability over the life of the machine.*

- ✓ *New features*



---

### **Buckets and Ground Engaging Tools**

Choose from three bucket families, General Excavation, Rock V-edge and Universal, combined with a large variety of Ground Engaging Tool options to allow precise application match. **pg. 14-16**

---

### **Work Tools and Quick Couplers**

Add versatility to your machine with a wide range of attachments and special buckets offered by Caterpillar.

- ✓ *Dedicated Quick Coupler actuation circuit.* **pg. 17**

---

### **Serviceability**

Easily perform daily maintenance up to 250-hour service intervals with ground-level access to all major service points including sight gauges for level checks of engine coolant, hydraulic and transmission oil. *Engine oil change interval* is increased to 500 hours and *hydraulic oil change interval* to 4000 hours thus decreasing service time and reducing owning and operating cost. The tilting hood provides unmatched access to the engine compartment and cooling system.

- ✓ *Engine oil change interval* is increased to 500 hours
- ✓ and *hydraulic oil change interval* to 4000 hours thus decreasing service time and reducing owning and operating cost. The tilting hood provides unmatched access to the engine compartment and cooling system. **pg. 18**

---

### **Environmental Machine**

Availability of Cat biodegradable hydraulic oil, combined with easy serviceability help you meet or exceed worldwide regulations and protect the environment. Axle ecology drains (optional), avoiding oil spillage.

**pg. 13**

---

### **Preventive Maintenance**

- ✓ Thanks to the new *Electronic Monitoring System*, the Electronic Technician, the Scheduled Oil Sampling analysis and the *Caterpillar Product Link system*, you can anticipate potential problems and avoid unscheduled repairs. **pg. 19**



## 3126B ATAAC Engine

*The six-cylinder, HEUI, turbocharged and-air-to-air aftercooled engine is built for power, reliability, low maintenance, excellent fuel economy and low emissions.*



### Powerful performance.

The 3126B ATAAC engine delivers, at the rated speed of 2200 rpm, the net power of 152 kW (204 hp), and meets all current worldwide emissions standards.

**HEUI Fuel System.** In the traditional common rail fuel system, the entire fuel line is under high pressure. With the HEUI system, fuel remains at low pressure until it is injected into the cylinder. Fuel pressure is created hydraulically in response to a signal from the Electronic Control Module (ECM).

### HEUI controls injection pressure electronically.

This unique capability means the regulation of injection pressure is completely independent of crankshaft speed. Peak injection pressure can be achieved under acceleration and lug conditions, providing better fuel economy, better response and reduced smoke.

**Three valves.** Three valves per cylinder allow for good air flow enhancing fuel efficiency and heat rejection.

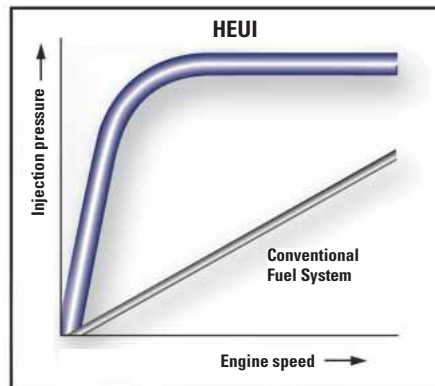

**Injection pressure in a HEUI fuel system is independent of engine speed.**

**Advanced fuel system.** The advanced Diesel Engine Module (ADEM III) fuel system is a Caterpillar exclusive electronic control module which provides improved engine response, performance, fuel efficiency, troubleshooting, diagnostics, and reduced emissions. The ADEM III electronic engine control improves altitude capability to 3050 meters without deration and allows integration with the electronic transmission control for maximum power train efficiency.

### Turbocharged and Air-to-air aftercooled.

Turbocharger packs more dense air into the cylinders for more complete combustion and lower emissions improving performance and engine efficiency. These benefits are especially useful at high altitudes. Air-to-air aftercooler reduces smoke and emissions by providing a cooler inlet air for more efficient combustion. This also extends the life of the piston rings and bore.

**Cooling system.** It features an electronically controlled continuously variable on-demand fan. Fan speed is determined by engine coolant, transmission oil, hydraulic oil, and inlet manifold temperatures. Cooler operating conditions mean lower average fan speeds resulting in reduced fuel consumption, lower noise levels, and less radiator plugging. The electronic engine control continuously compensates for this varying fan load providing constant net horsepower for consistent power regardless of operating conditions. Hydraulic oil cooler, air conditioner condenser, and rear grill are all hinged for easier cleaning. Side panels allow access to both sides of all cores for easier cleaning.

**Crankshaft.** It is steel-forged, carburized, and induction-hardened for long-term durability. It is dynamically balanced for smooth operation. The crankshaft is completely regrindable. Connecting rods can be removed through the tops of the cylinders for servicing ease.

**Caterpillar engine oil.** It is formulated to optimize engine life and performance and is strongly recommended for use in Cat diesel engines. The engine oil change interval is increased to 500 hours.

**Factory remanufactured parts.** A large choice of factory remanufactured parts and dealer proposed repair options increase machine availability and reduce total repair costs.

# Electronic Transmission

*Caterpillar power train makes dependable performance a standard feature.*

## Electronic power shift transmission.

The Electronic power shift transmission with automatic shift capability is designed, developed and built by Caterpillar. The electronically controlled power shift transmission allows full-power, speed and directional changes. Fully modulated gear shifts significantly contribute to the operator comfort and increase machine productivity as well as component life.

## Electronic Clutch Pressure Control (ECPC).

It senses input from both the transmission and the operator controls in the cab to modulate each individual clutch through a proportional electro-hydraulic valve. This results in smoother shifts in both speed and direction. Energy is modulated into the clutches, resulting in longer clutch life.

**Integrated Braking System.** It integrates a downshifting and neutralizer logic into the left-hand brake pedal. This system translates into increased performance/productivity for the operator thanks to the optimized transmission neutralizer, the automatic downshifting and downhill retarding feature. The Integrated Braking System also lowers the owning and operating costs thanks to reduced axle oil temperatures, which can extend the brake life.

- A** Downshift logic only
- B** Brake application initiated
- C** Self-adjusting transmission neutralization

## Single-stage torque converter.

The torque converter has stall ratio of 2.83:1. An optional attachment is the Free Wheel Stator torque converter, which operates just as a conventional torque converter until the speed of the turbine (output) is approximately 85% of the speed of the impeller (input). At this point, a one-way clutch releases the stator allowing it to freewheel in the same direction as the impeller and turbine. The attachment Free Wheel Stator increases efficiency resulting in lower torque converter oil temperature and improved fuel economy.

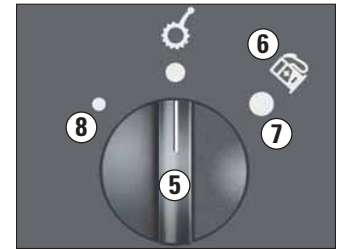
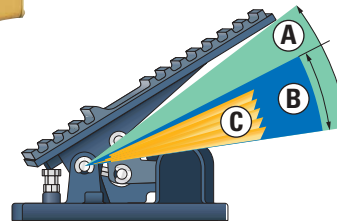
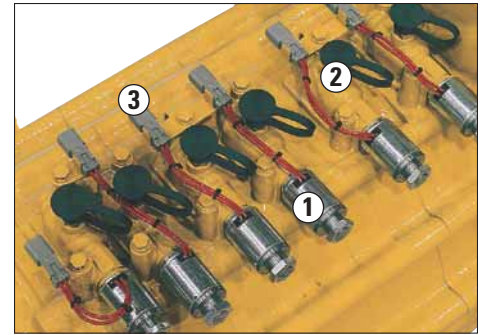
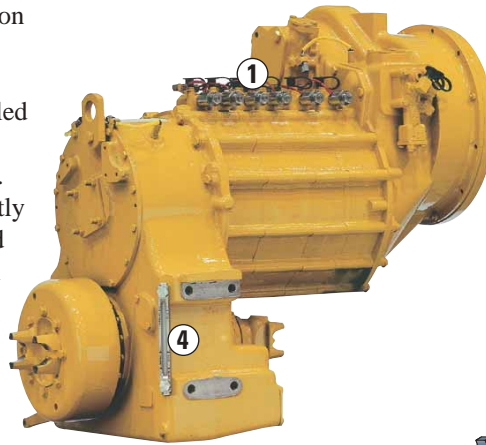

## 1 Electro-hydraulic valves.

The six proportional electro-hydraulic valves pressurizing the clutches are identical and bolted on top of the transmission.

## 2 Dedicated pressure port.

It is fitted on each electro-hydraulic valve to help reduce troubleshooting time for increased machine availability. By connecting the Electronic Technician (ET) and the service tool box, the transmission can easily be recalibrated to maintain quick response (see also page 19).

## 3 Thermoplastic connectors.

Heavy-duty thermoplastic connectors, sealed against moisture and contaminants, ensure reliable and trouble-free connections with the transmission control.

## 4 Easy service.

Easy service is built in the transmission. The daily level check is done from ground level through a well-protected sight gauge. An oil sampling valve allows quick, clean access to the transmission for S•O•S oil analysis.

## 5 Variable Shift Control.

A transmission software which allows the operator to select three different shift patterns based on his application and operating preference. This feature reduces fuel consumption depending on the application. In all modes, the full machine power remains available for loading.

- 6** ISO symbol for fuel efficiency
- 7** Economy mode (typically used for load and carry and roading applications)
- 8** Aggressive mode (typically used for tight truck loading applications)

**Caterpillar transmission oil.** It has been developed to provide optimum friction control for power shift transmissions and brake disc material, as well as, to optimize transmission and final drive gear life.

**Transmission neutralizer.** It allows the operator to disengage the transmission clutches, removing torque from the drive train. With the neutralizer, high engine rpm's are maintained for full hydraulic flow and brake drive through is prevented.

# Axles

Large, heavy-duty axles protect internal components from the harsh environment and offer excellent serviceability and maintenance.

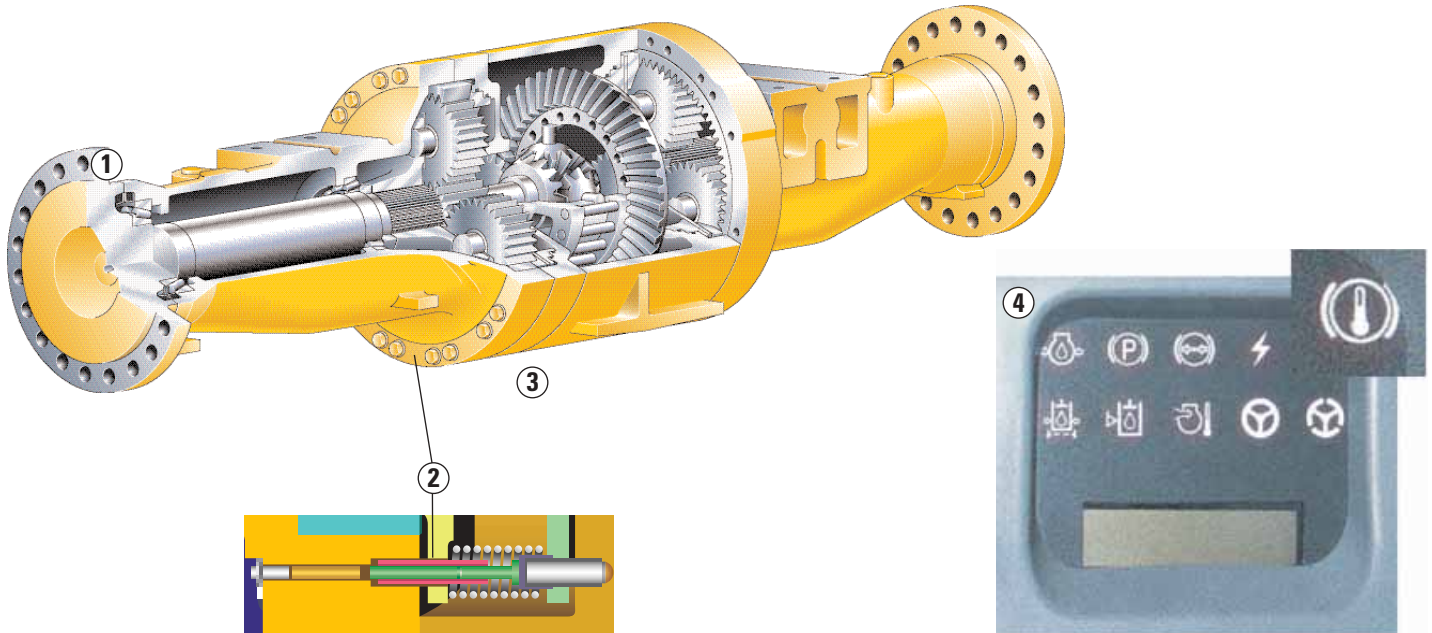

## Heavy-duty axles and brakes.

Designed to last in all kinds of operating conditions. Planetary final drives use free-floating, bronze sleeve bearings in the planet gears.

- The differential pinions use free-floating bronze sleeve bearings, and bronze spherical thrust washers for increased durability.
- Multiple oil-disc brakes are adjustment free and fully enclosed to lock out contaminants.

**Front axle.** It is rigidly mounted to the frame to support the weight of the wheel loader, internal torque loads and external loads applied during breakout and loading.

**Rear axle.** It includes a trunnion, two trunnion supports and the associated bearings, allowing it to oscillate plus or minus thirteen degrees, ensuring four-wheel ground contact for traction and stability, even on rugged terrain.

**Limited slip differentials.** Deliver maximum traction on uneven ground and in changing traction conditions such as mud, water, snow and ice. They are available for front and/or rear axles.

**1 Duo-Cone Seals.** Patented metal-to-metal, Duo-Cone Seals between the axle shafts and housings keep lubrication in and dirt out.

**2 External port.** An external port (patented) provides access to measure brake disc wear without disassembling the axle. The original brake measurement is recorded in the machine controls at the factory to allow precise wear calculation and schedule appropriate service.

**3 Four-piece axle.** It contains two axle shaft housings, the center housing, and the intermediate housing. Features and benefits of this design include:

- Inboard brakes are positioned immediately adjacent to the differential and operate on the low torque side of the final drive, requiring less braking force to stop the machine.
- Independent front and rear brake circuits use separate, heavy-duty, piston-type accumulators to ensure dead engine braking.
- Brakes are bathed in axle oil for excellent cooling.
- Brakes can be serviced without disassembling the final drive.
- Larger diameter axle shafts on high torque side of final drive provide greater torsional strength for better performance and durability.

**4 Axle oil temperature sensor.**

Oil temperature sensors in both front and rear axles alert the operator when oil temperatures are too high and a change in operating technique is required or slowing the machine. When an over-temperature situation is detected, the sensors illuminate an LED on the Electronic Monitoring System (EMS III) panel.

**Axle oil Ecology drains.** Axle oil Ecology drains and axle oil coolers are available.

## Frame

*Superior engineering and materials provide excellent strength and durability.*

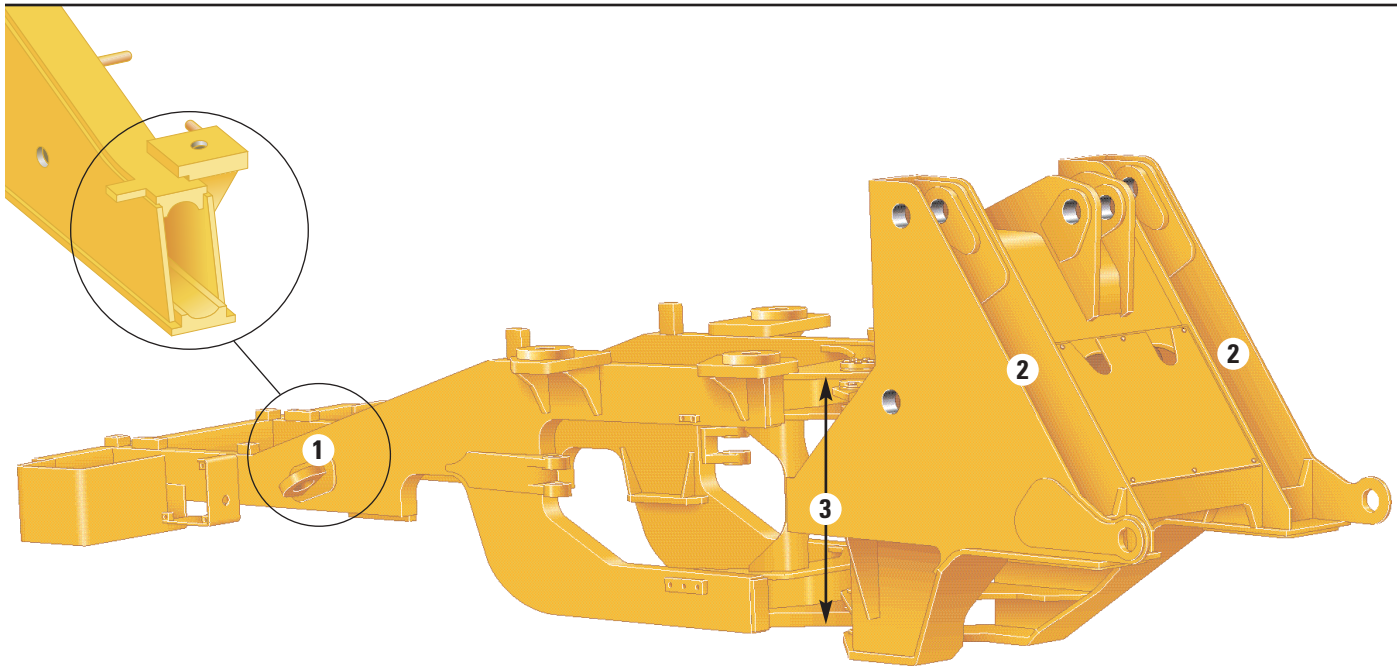

**1 Full box-section rear frame.** Designed to resist twisting and impact forces and serve as a strong base for the engine, transmission and rear axle. New sealed battery and tool box to prevent dirt and moisture entry.

**2 Four-plate loader tower.** Providing a solid foundation for lift arms, lift and tilt cylinders and front axle. This structure is built to resist severe torsional, impact and loading forces.

**3 Spread-hitch design.** It widens the distance between upper and lower hitch plates to distribute forces and increase bearing life. Thicker hitch plates and butterfly support reduce deflection. The wide opening allows good service access.

**Hitch pins.** Upper and lower hitch pins pivot on double-tapered roller bearings. This design distributes vertical and horizontal loads over a greater surface area for longer life.

### Frame structure

- Increased machine stability without sacrificing turning radius.
- Better loader performance and operating specifications.
- Improved serviceability to frame and components.

**Severe applications.** Frames were tested under severe applications including rock, hardbank digging, load and carry, bump course travel and bucket corner loading.

# Hydraulics

*Well balanced hydraulics deliver precise, low-effort control and trouble-free operation.*



## **Low-effort hydraulic controls.**

Allow the operator to precisely maneuver bucket lift and tilt.

### ■ **Electro-hydraulic controls.**

Packaged together with Command Control steering, offer extremely low “finger-tip” lever efforts and unparalleled steering comfort. Automatic lift and tilt kickouts are switch-adjustable from the seat to easily meet application requirements, allowing the operator to set and adjust the raise, lower, and tiltback kickout. The lift and tilt kickouts are hydraulically cushioned for greater operator comfort and less material spillage. The electro-hydraulic controls offer additional enhancements available for the first time with the 962G Series II. The improvements include “bucket dump rate control” for smooth flow of material from the bucket and a switch for “fine modulation control” to provide precise control for delicate bucket or work tool operations.

### ■ **Electro-hydraulic control**

**enhancements.** Including dump rate control to check bucket dump speeds. Fine modulation control provides very precise control for delicate bucket or work tool operations.

### ■ **Pilot valve hydraulic controls.**

Packaged with a conventional steering wheel, provide low lever efforts along with a familiar steering system. One lift and one return-to-dig position may be adjusted on the linkage.

### **Smooth, efficient steering.**

Load sensing steering maximizes machine performance by directing power through the steering system only when needed. When the machine is not steering, more engine power is available to generate rimpull, breakout and lift forces. Load sensing reduces horsepower draw by up to 8 percent, resulting in increased fuel economy. Large-bore steering cylinders allow responsive maneuverability.

**Hydraulic pumps.** Perform with high efficiency and great reliability. High flow rates result in fast hydraulics, for an optimum balance between machine ground speed and hydraulic lift speed, especially important in tight truck loading.

**Pressure taps.** Remote pressure taps are available to make diagnosis even easier and faster and diagnose hydraulic system components.

### **Caterpillar’s XT hose and couplings.**

Uniquely designed and tested to work together as a system for superior performance. Hoses are engineered and manufactured for high abrasion resistance, excellent flexibility and easy installation. Caterpillar couplings use pre-installed O-ring face seals which provide positive sealing for durable, leak-free connections. Reliable components reduce the risk of leaks, helping protect the environment.

### **Advanced Automatic Ride Control**

**attachment.** It helps operators perform better. A nitrogen over oil piston-type accumulator in the hydraulic lift circuit acts like a shock absorber for the bucket or work tool when traveling over rough ground. This reduces fore and aft pitch for a smoother, more comfortable ride. It also gives operators the confidence to travel at higher speeds during load and carry cycles improving cycle times, load retention and productivity.

### **Caterpillar hydraulic oil.**

Maximum protection against mechanical and corrosive wear in all hydraulic systems. Its high zinc content reduces wear and extends pump life. Provided certain requirements are met (e.g. S•O•S analysis every 500 hours), the hydraulic oil change interval is extended from 2000 hours to 4000 hours.



## Operator Controls

*Low-effort controls ease machine operation for increased comfort and efficiency.*



**Two different control configurations.** The 962G Series II is available with two different control configurations – Command Control steering with electro-hydraulic implement controls, or Conventional steering with pilot hydraulic implement controls.

**1 Command Control steering.** Allows one hand operation of steering and transmission controls. Turning the Command Control steering plus or minus 35 degrees, left or right, from centerpoint, achieves full machine articulation. Steering stops are hydraulically cushioned. Tilt and telescoping steering column helps fit the controls to the operator.

**2 Integrated transmission controls.** They are part of the steering design. Select forward, neutral or reverse with the three position rocker switch. Use the thumb-operated rocker switch to manually up-shift and downshift.

**3 Finger tip implement control levers.** Require low operator effort and reduced travel. Operator can slide the right-hand armrest and control pod forward and back as a unit, and adjust the armrest cushion up and down to find the most comfortable position.

**4 Conventional steering and pilot hydraulics configuration.** Conventional steering (standard) uses a well-proven, hand-metering-unit hydraulic system. The lift control lever features a quick gear kick-down button, which lets the operator downshift easily to a lower gear. This version is also available with an optional third lever control.

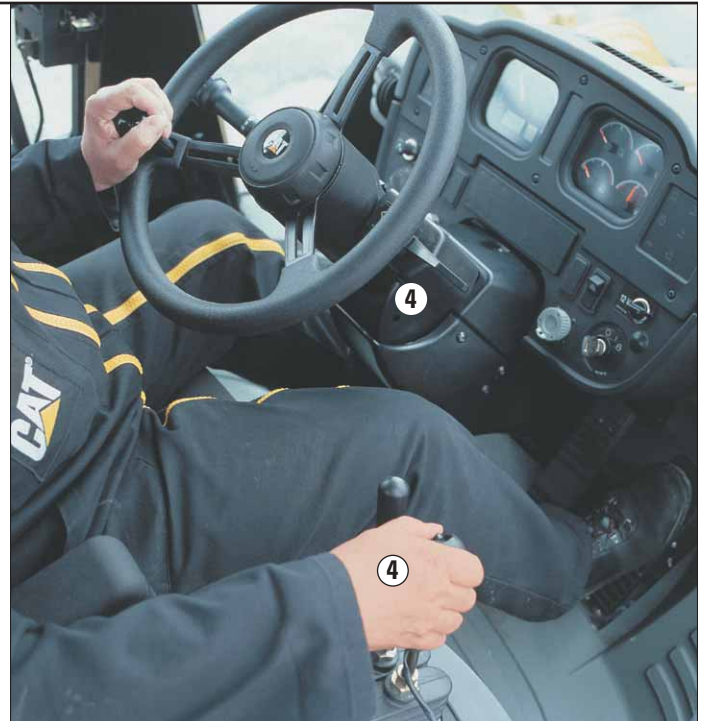

**Electronic transmission mode switch.** Allows the operator to concentrate on the work, not on gear selection.

- **Command Control steering:** the operator selects either manual mode or auto mode. In auto mode, the operator can choose the highest gear the transmission will automatically up-shift to (2nd, 3rd or 4th) using the console-mounted switch. The transmission up-shifts (depending on the selected Variable Shift Control mode) so that each shift occurs at optimum torque and ground speed.
- **Conventional steering:** The operator selects either manual mode or auto mode. The maximum gear the transmission will automatically up-shift to (2nd, 3rd or 4th) can be selected using the rotating gear selector on the shift lever.

**Dual-pedal braking.** It lets the left pedal function as a brake, incorporating the Integrated Braking System, but also integrates a transmission neutralizer and an automatic downshift logic (see also pg. 5). The right pedal functions as a regular brake. With the neutralizer, the operator can maintain high engine revolutions for full hydraulic flow (see also on pg. 10).

**Transmission neutralizer lockout.** It lets the operator shut the neutralizer off. This provides a choice to operators who prefer to operate without a neutralizer. It also provides excellent inching capability for utility work.

## Operator Station with Command Control Steering configuration

*The ultimate in wheel loader operator comfort and efficiency.*



***The ultimate in wheel loader operator comfort and efficiency.***

*The new 962G Series II cab, builds on the G-Series reputation for operator comfort with several enhancements. The cab includes outstanding visibility, ergonomic automotive-style controls placement, improved ventilation and generous storage areas.*

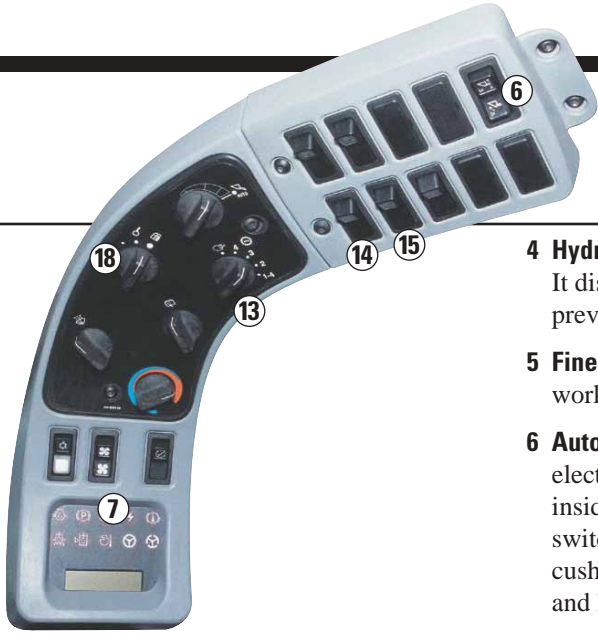

### 1 Command Control steering.

It is optional and features a steering wheel, with integrated transmission controls. Ergonomically integrated into the controls are two rocker switches, one for the forward/neutral/reverse selection, the other for manual up/down shifting. Load-sensing steering matches steering response to application requirements. Tilt and telescopic steering column helps fit the controls to the operator.

### 2 Excellent viewing in all directions.

The wider front window opens the operators view for remarkable forward and peripheral viewing including machine wheels and bucket corners. It also increases the area cleared by the windshield wiper. Bonded glass in the windshield eliminates frame obstructions. The stylish, sloping hood improves the view to the rear by letting the operator see objects closer to the machine. The larger roof improves water run-off and provides better protection against glare.

**3 Finger tip controls.** Electro-hydraulic, finger tip, implement controls are optional and feature low effort, precise hydraulic modulation capability. The controls are seat-mounted and adjustable for outstanding ergonomics. This attachment is packaged with Command Control steering.

### 4 Hydraulic control lockout switch.

It disables the hydraulic levers to prevent accidental (dis)engagement.

**5 Fine modulation mode.** For precise work tool control.

**6 Automatic lift/tilt kickouts.** Part of the electro-hydraulic controls, adjust from inside the cab with a simple rocker switch. Kickout stops are hydraulically cushioned for greater operator comfort and less material spillage.

### 7 962G Series II new Monitoring System.

It consists of gauges, tachometer/speedometer and 3-level warning to ensure full time monitoring of key functions. The system alerts the operator of immediate or impending problems with engine oil pressure, parking brake, axle oil pressure, electrical system, brake oil temperature, hydraulic oil level, hydraulic filter bypass, engine inlet manifold temperature, primary and secondary steering oil pressures. Indicators consist of LED (Light Emission Diodes) with no bulbs to replace.

**8 Left, rear-hinged door.** It includes a sliding window. The re-designed door latch allows the operator to open/close the door either from ground level or when seated in the cab. The right-side plain glass window provides outstanding visibility to the side of the machine and serves a secondary exit if needed. The window opens partially for additional ventilation.

**9 Dual brake pedals.** Incorporates Integrated Braking System that serve brake, transmission neutralizer and downshift functions so the operator can maintain high engine revolutions for full hydraulic flow and high productivity.

### 10 Generous storage space

- Coat hook.
- Molded compartments for lunchbox, cooler, thermos, cup or can.

### 11 New Caterpillar Comfort air suspension seat.

Standard on the Command Control steering version and optional on the Conventional steering wheel version, 6-way adjustable. The seat cushions reduces pressure on the lower back and thighs, while offering unrestricted arm and leg movement. Air suspension adds to overall comfort by smoothing the ride over rough terrain. Seat is equipped with a 76 mm retractable seat belt.

**12 Improved ventilation.** Better air flow to the operator and windows. There are thirteen louvered vents with two on each door post. A large re-circulation filter ensures better air quality and contributes to operator comfort.

**13 Electronic transmission mode switch.** Settings from manual to fully automatic.

**14 Ride Control System switch.** Allows the selection of three different modes:

- Off: permanently off service.
- On: permanently in service.
- Auto: in this mode, the system is automatically actuated when the machine travels at a speed greater than 9 km/h (which is adjustable) and will be turned off below 9 km/h.

**15 Transmission neutralizer lockout switch.** A momentary rocker that defaults to neutralizer active upon machine start up.

**16 Radio ready.** It includes a 12-volt converter (10-amp), speakers, antenna, all wiring and brackets for entertainment or communications radio installation.

**17 Exterior rear-view mirror.** Package includes two large, curved mirrors, solidly mounted on strong brackets to keep them well adjusted and avoid vibrations.

**18 Variable Shift Control.** Allows the operator to select three different shift patterns based on application and working preferences.

**19 Improved floor.** For easier cleaning.

### Other options

- Air conditioning
- Internal mirrors
- Working lights
- Payload Control System

## Operator Station with Conventional Steering configuration

The new G Series II cab, provides comfort and ergonomic controls to help maximize productivity.



**1 Low-effort conventional steering wheel.** It offers a good grip and tilts for maximum comfort.

**2 Hydraulic implement controls.** Pilot-assisted, hydraulic implement controls make low-effort operation possible.

**3 Quick gear kickdown button.** Lets the operator downshift easily to a lower gear, saving time, increasing bucket fill factors and lowering cycle times.

**4 Adjustable wrist rest.** Padded, adjustable wrist rest helps reduce fatigue.

**5 Seat options.** The standard seat has adjustable fore/aft position, seatback angle, lumbar support, bottom cushion height, armrest angle and suspension stiffness. The seat trim is a combination of durable fabric and vinyl. Available as an option is the Caterpillar Comfort air suspension seat featuring added support and an electrically adjustable air suspension. Both seat versions are equipped with a 76 mm retractable seat belt.

### **6 Generous storage space**

- Coat hook.
- Molded compartments for lunchbox, cooler, thermos, cup or can.
- Integrated storage in the hydraulic implement controls console.

### **Other options for the 962G Series II operator station**

- Air conditioning that uses blended air for quick temperature changes and R-134a refrigerant which does not contain chlorofluorocarbons. Quick-connect couplings allow easy removal from the cab with no release of refrigerant.
- Internal mirrors package.
- Payload Control System.
- Working lights.
- Caterpillar Comfort air suspension seat.
- Lift Lever F-N-R switch.

## Environmental Machine

*Caterpillar cares about the environment and continues to develop innovative solutions.*



### Machine Features

- An on-demand fan (standard on all 962G Series II), which automatically regulates the fan speed depending on the cooling requirements.
  - Additional sound insulation around the engine.
  - Oil sampling valves and pressure test ports for service diagnostics.
- These features result in reduced operating cost, quieter machine, and easier service.

### Environmental Fluids

- Extended Life Coolant/Antifreeze with anti-foaming and anti-corrosion properties provides extended service intervals (up to 6000 hours) requiring less frequent fluid renewals and disposals. This is a standard feature.
- Cat Bio Hydo (HEES) is formulated from a fully saturated Hydraulic Environmental Ester Synthetic base stock and selected additives. It has excellent high-pressure and high-temperature characteristics. Provided a special water separator filter has been installed and depending on regular S•O•S analysis, Cat Bio Hydo (HEES) service intervals can be extended up to 6000 hours. It is fully compatible with our hydraulic components and allows operation over a broad temperature range. Cat Bio Hydo (HEES) is fully decomposed by soil or water microorganisms. This is available as an attachment.

**Low exhaust emissions.** The Cat 3126B ATAAC engine used in the 962G Series II is a low emission engine designed to meet current emission regulations. Electronically controlled engine adjusts the fuel-to-air ratio and the air-to-air aftercooler provides more efficient combustion, lower fuel consumption and cleaner emissions.

**Fewer leaks and spills.** Transmission and hydraulic oil filters, as well as engine oil and fuel filters are spin-on elements, positioned vertically and purposely located for a quick and easy access allowing their removal without fluid spillage. Lubricant fillers and drains are also designed to avoid spills.

**Ecology drains.** They are standard from factory for the engine, transmission, hydraulics, radiator and fuel. They replace the standard drain plugs. Activating the valve allows fluid to be drained into a container without spillage. Axle oil ecology drains are optional and allow quicker oil changes, eliminate spillage and reduce the time/risk of clean up.

**Rebuildable components.** Many of the major components used in the 962G Series II are designed for rebuildability. That means you have high-quality, remanufactured (REMAN) parts available to you at a fraction of the new component cost.

## Cat Buckets and Ground Engaging Tools

Three bucket families and a large choice of Ground Engaging Tools maximize performance in all applications.

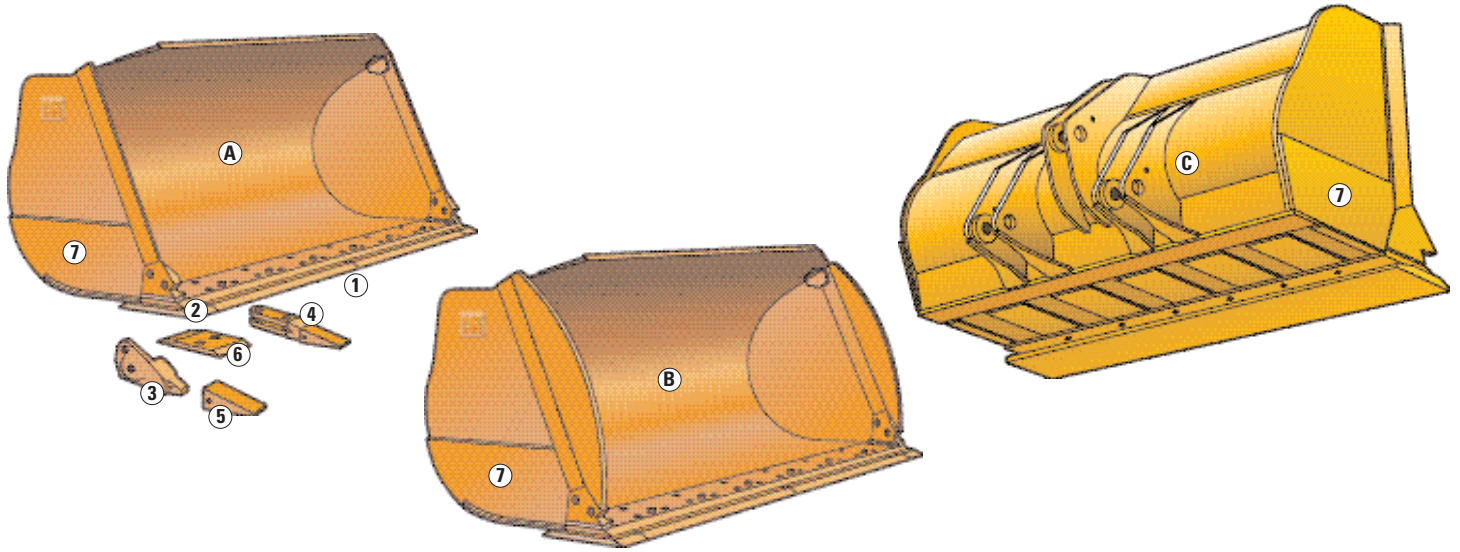

### A Standard Universal buckets.

This is a new line of flat floor buckets featuring an optimized design. Equipped with various Ground Engaging Tools, they provide easier pile penetration, better fill factors and faster loading cycles; they are offered in a wide range of capacities and are recommended in all applications, except fulltime bank or rock loading. All buckets feature integral spill plates to prevent rear spillage, as well as, bottom and side wear plates for greater durability. In order to better meet the various application criteria, the Universal bucket line is available in different configurations:

### B Universal buckets with Rounded Side Plates.

This provides an excellent load retention in aggregates application, especially in load-and-carry cycles.

### C Universal buckets with Back Grading Edge.

In this configuration, an additional full-width box-section profile with a wear edge is welded at the back of the bucket floor. The bucket base edge and the additional rear edge are at the same level, providing better grading capabilities. This bucket can be fitted with welded flush mounted adapters and tips still allowing excellent grading capability.

**Corner guard system.** Allows maximum flexibility between teeth and edge systems for superior protection and performance in each application.

#### Bolt-on cutting edge (1) and end bits (2)

- Standard DH-2, reversible, for superior strength and wear life.
- Heavy-duty, reversible, providing 50% more wear life.
- Abrasion Resistant Material (ARM) with impregnated tungsten carbide is another option for maximum wear life in low-to-medium impact application.

#### Bolt-on teeth

- New two-bolt corner adapter (3) securely attached to prevent shifting.
- Bolt-on two-strap center adapters (4).
- Seven tip options with Heavy-duty retention system. (5).

#### Bolt-on teeth and edge segments

- Standard reversible segments (6) protect the base edge between teeth, eliminating scalloping and maintaining a smooth work surface.
- Heavy-duty reversible segments for 50% more wear life.

**Side wear plates.** Replaceable side wear plates (7) for greater durability.

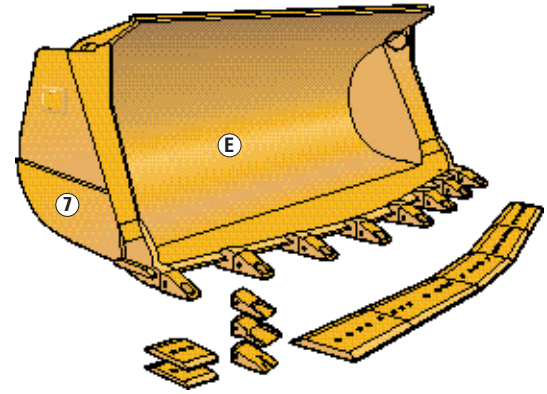
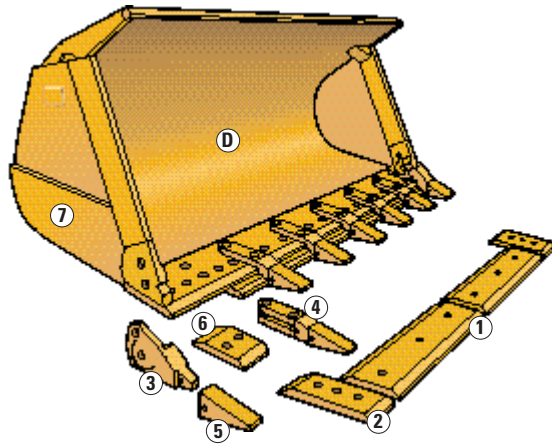

**D General Excavation Buckets.**

All General Purpose buckets have been renamed as General Excavation buckets to better reflect their application spectrum. Built to handle the toughest conditions, they feature a well proven, shell-tine construction design that resists twisting and distortion and are excellent for bank and excavation applications. Bucket hinges are part of a structure that extends under the bucket shell to the cutting edge, forming box

sections. These structures act as protection against impact and twisting forces. All buckets have integral spill plates that prevent rear spillage, keeping material away from the linkage. Replaceable through-hardened weld-on rear wear plates protect the bottom of the bucket for greater durability. Bucket side plates are also reinforced in their lower portion with additional wear plates for longer life.

**E Rock Buckets.**

Cat rock buckets are built to tough standards. The spade-edge design provides easier penetration and makes them well suited to high-impact jobs. Ground Engaging Tools include bolt-on cutting edge or weld-on two straps adapters to be fitted with J350 tips, with or without standard or heavy-duty bolt-on segments.

# Tip Selection and GET System Selection Guide

Seven tip options are available to provide the best combination of wear life, penetration and strength needed for each application.

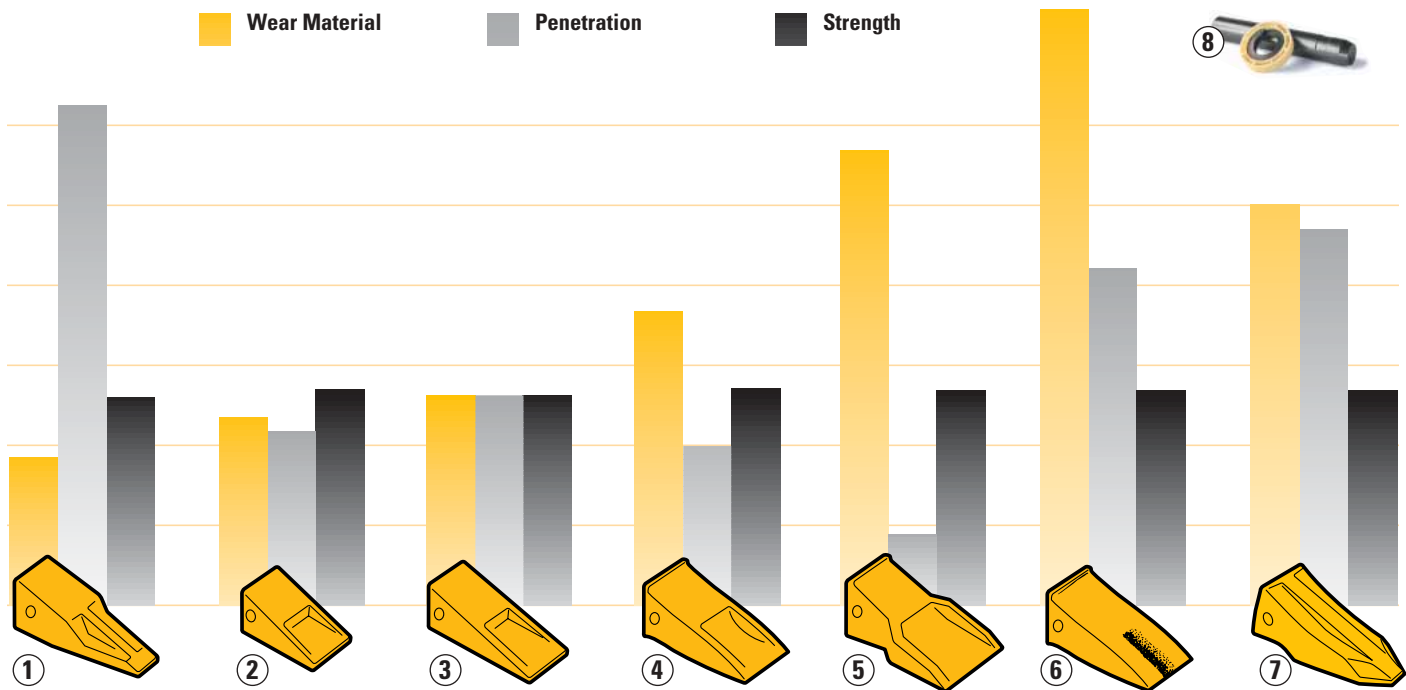

## 1 Penetration

- Use in densely compacted material such as clay.
- Gives maximum penetration.
- Self-sharpening.

## 2 Short

- Use in high-impact and pry-out work such as rock.
- Extremely strong.

## 3 Long

- Use in most general applications where breakage is not a problem.

## 4 Heavy Duty Long

- Use in general loading and excavation work.
- Has extended wear life and greater strength

## 5 Heavy Duty Abrasion

- Use when working in sand, gravel and shot rock.
- Maximum wear material.

## 6 Heavy Duty Long Life

- A.R.M. positioned to increase wear life and penetration.
- As the Heavy Duty Long Life tip wears, ease of penetration increases.

## 7 Heavy Duty Penetration

- Use in high-impact, hard-to-penetrate material.
- Extended wear life.
- Good combination of strength and wear life.

## 8 Heavy Duty retention system

Eliminates pin walking and the resultant tip loss in particularly severe loading conditions.

## GET system selection guide

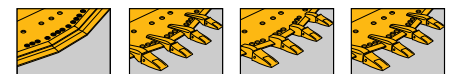
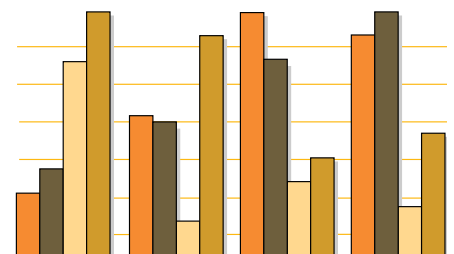

Cutting edges (bolt-on or weld-on)    Flushmount adapters    Bottom-strap adapters    Two-strap adapters

- Penetration ability
- Impact resistance
- Wear life/Abrasion protection
- Smooth floor maintenance



## Work Tools and Quick Couplers

Add versatility to your machine with a wide range of special buckets and quick couplers designed for the 962G Series II to optimize your operation.



**1 Quick couplers.** Providing unmatched versatility and allows one operator with one machine to perform a wide variety of tasks, resulting in greater machine performance and cost efficiency. Use the dedicated quick coupler actuation circuit (optional) to activate the quick coupler and change mechanical tools without leaving the cab. Having a dedicated circuit also leaves the third valve solely to actuate hydraulic tools without the need for diverter valves. The benefits of the vertical wedgelock quick coupler are:

- Minimal loss of break-out force
- Automatic adjustment for wear
- High durability

**2 Coal buckets.** Available in special widths. All coal buckets include a bolt-on cutting edge.

**3 Woodchip buckets.** Specially designed to load and carry woodchips and similar light materials. Bolt-on cutting edges are included as standard. Visibility screens help the operator with loading.

**4 Multi-purpose buckets.** Loading, dozing, clamping objects or filtering the discharge of material are easy tasks with multi-purpose buckets.

**5 High-dump buckets.** Ideal for applications as various as loading stockpiled, light material into high sided trucks, hoppers in waste transfer stations or rehandling fertilizer, coal or grain.

**6 Side-dump buckets.** Permit loaders to operate in congested worksites and also dump forward like conventional buckets.

**7 Forks.** Pallet, forks are the ideal tools for handling a variety of materials.

**8 Log fork with top clamp.** For tree length or cut to length logs. Lumber and log forks are also available.

**9 Material handling arm.** Material handling arm with adjustable lengths and load capacities, provide a boom for placing material from overhead – great for lowering pipes and beams into position on construction projects.

**Fertilizer buckets.** They can be designed for different hopper heights, widths and intake capacities. The special design allows fertilizers to spread in the bucket filling in the whole volume.

**Brick and clay buckets.** Ideal for the handling of sticky materials like clay and gypsum. They are fitted with specific linings, featuring low coefficient of friction and good abrasion resistance.

**Screening buckets.** Allow operators to scoop, screen, blend, mix and load materials as various as top soil, clay, sand peat, compost, bark, coal, lime, glass bottle... Different screening drums and tool options are available.

**Plows.** Hydraulic reversible plows angle 30°, left or right. This reversing action is ideal for cleaning applications on mountain roads, airports, parking lots, plant facilities, etc.

A complete range of attachments and tools is available from your Caterpillar dealer.

## Serviceability

*Keep machines up and running with easy-to-perform daily maintenance.*



**Maintenance.** It has never been more accessible than on G-Series II machines. Fast, easy and reduced maintenance means improved uptime and greater value.

- Lockable, ground level service doors give quick access to engine oil fill and dipstick, coolant sight gauge, air filter indicator, rear grease fittings, and battery disconnect switch. Sight gauges for hydraulic and transmission oil levels are also easily viewable from the ground.
- Oil cooler and optional A/C condenser swing out, allowing quick easy cleaning of the engine radiator. The air flows first through the hydraulic oil cooler and the optional A/C condenser, then through the engine multi-row radiator and is rejected through three perforated panels.
- Grouped remote grease fittings allow ground level access for lubricating tilt and steering cylinder pins and rear axle oscillation bearings.
- Caterpillar fluid filters are especially designed to assure maximum component life. The unique design uses non-metallic centertube and molded end-caps, which fully blend with media ensuring no internal leakage.
- Cat high efficiency fuel filters with STAY CLEAN VALVES™ feature cellulose/synthetic blend media that remove more than 98 percent of particles that are two microns or larger, maximizing fuel injector life.
- Caterpillar Radial Seal air filters do not require tools to service, reducing maintenance time. The ultra-high efficiency primary air filter element is coated with a fine layer of fibers that prevent dust particles from entering

the filter media. This results in more efficient filtration, extended service intervals, and extended filter life – all contributing to reduced operating costs.

- Caterpillar Extended Life Coolant allows extended change intervals (6000 hours).
- Caterpillar maintenance-free, high output batteries are designed for high cranking power and maximum protection against vibration.
- Individual Multi-Row Modular core radiator reduces time to repair or replace the radiator.
- G-Series II machines feature a brake wear indicator port.

### Reliability and durability

- **Paint Process.** Great care is given to ensure a durable paint finish. Most brackets and other hardware are zinc-plated. Larger components are all prime painted, the cab receiving a zinc-phosphate based coating to prevent rust. The entire machine, as well as decals, is finish painted with a clear, two-component, polyurethane based paint which provides a durable, UV resistant, high gloss.
- **Electrical Systems.** Designed and manufactured to resist the most severe conditions. Harnesses are made of large-section, colored and number-coded wires, the complete harness being protected by an abrasion resistant braiding. Connectors are made of rugged thermoplastic or cast-aluminum shells, sealed against moisture and contaminants. Harnesses are properly routed and securely clamped to ensure their reliability and durability.

**Sloped hood.** It is electrically or mechanically activated, tilts up for complete access to the engine, cooling system and other major components. If needed, the hood can be removed quickly and easily by removing three pins and disconnecting a single harness connector. A built-in lifting point facilitates easy lift off.

### Automatic Greasing System

**attachment.** It supplies the required quantity of grease at the right interval to the grease points automatically, without manual interference. It greases while the machine is in operation, resulting in better distribution of grease over the bearing surface. Also, the automatic greasing reduces downtime, repair and overhaul costs, safety and environmental hazards and greasing costs (up to 75%). The automatic greasing system is optional and being factory installed prior to final assembly.

### Engine, transmission, hydraulic oils.

Caterpillar engine, transmission and hydraulic oils deliver maximum performance and service life. The oil change intervals are extended to 500 hours for engine oil and 4000 hours for hydraulic oil (provided certain conditions are met) limiting service time and lowering owning and operating costs.

### Factory remanufactured parts.

A large choice of factory remanufactured parts and dealer proposed repair options increases machine availability and reduces repair cost.

## Preventive Maintenance

*By anticipating potential problems and avoiding unscheduled repairs, your equipment is always up and ready to run.*

### Electronic Monitoring System (EMS-III).

It monitors all key controls and functions. The system alerts the operator of immediate or impending problems with engine oil pressure, axle oil pressure, parking brake, electrical system, low fuel level, engine inlet manifolds temperature, brake oil temperature, hydraulic oil level, hydraulic filter and primary and secondary (if equipped) steering. In the service mode, the digital panel displays operating parameters, diagnostic codes and out-of-range gauge readings. It also calibrates the electronic lift and tilt controls as well as the electronic transmission controls.

More than 90 fault codes are already visible on the EMS-III screen in the cab. They are documented in the Operation and Maintenance Manual of the machine allowing you to identify directly where the potential defect has occurred.

- 1 ET software
- 2 Communications Adapter
- 3 Diagnostic Connector
- 4 Electronic Control Modul (ECM)

### Caterpillar Product Link system

**attachment.** It includes a transceiver module (on-board the machine), office application PC software, and a satellite communications network to track machine hours, location, and warnings (PL-201). Product Link simplifies maintenance scheduling, fleet management, unauthorised machine usage or movement, and product problem event tracking and diagnosis (PL-201).

Available in two versions, there is a Product Link system for most customers needs. See your Caterpillar dealer for details.



### Electronic Technician (ET).

Caterpillar Electronic Technician is a software program which allows the service technician to find and identify a problem on a machine and to analyze how to fix it quickly. ET provides him with the capability to access the Electronic Control Modules from a personal computer.

The Electronic Technician is used for:

- Viewing active and non active diagnostic codes and clearing them after repair.
- Displaying the status of all parameters such as engine speed, gear engaged, control levers position, control switch position, etc.
- Performing diagnostic test and calibrations of electro-hydraulic components.
- Viewing current configuration and changing parameter settings.
- Flashing new Caterpillar software in the Electronic Control Modules.
- Recording all parameters during machine operation.

A customer version of ET is also available for your fleet of Caterpillar equipment. Contact your Caterpillar dealer for more detailed information.

### Scheduled Oil Sampling (S•O•S)

**analysis.** Caterpillar has specially developed S•O•S to help ensure better performance, longer life and increased customer satisfaction. It is an extremely thorough and reliable early warning system which detects traces of metals, dirt and other contaminants in your engine, axle, transmission and hydraulic oil. It can predict potential trouble early, thus avoiding costly unscheduled failures. Your Caterpillar dealer can give you results and specific recommendations shortly after receiving your sample.

Each S•O•S test can provide specific types of diagnostic:

- **Oil condition analysis** identifies loss of lubricating properties by quantifying combustion products such as soot, sulfur, oxidation and nitrates.
- **Wear analysis** monitors components wear by detecting, identifying and assessing the amount and type of metal wear elements found in the oil.
- **Chemical and physical test** detect the physical presence of unwanted fluids (water, fuel, antifreeze).

## Engine

Four-stroke cycle, six-cylinder 3126B HEUI, turbocharged and air-to-air aftercooled diesel engine.

### Power and Torque

Flywheel power at 1900 rpm	157 kW	210 hp
Maximum flywheel torque at 1400 rpm	910 Nm	
Total torque rise	38%	

The following ratings apply at 2200 rpm when tested under the specified standard conditions:

Rated flywheel power	kW	hp
ISO 9249	152	204
EEC 80/1269	152	204

### Dimensions

Bore	110 mm
Stroke	127 mm
Displacement	7.2 liters

### Exhaust emissions

The 3126B meets the following emission requirements:  
EU directive 97/68/EC Stage II

### Power rating conditions

- net power advertised is the power available when the engine is equipped with hydraulic fan drive, alternator, air cleaner, and muffler
- no derating required up to 3050 m altitude

### Features

- Caterpillar exclusive Advanced Diesel Engine Module (ADEM III) electronic fuel system control module is fully integrated with other electronic control modules on the machine for improved performance
- Caterpillar state-of-the-art hydraulically actuated, electronically controlled unit injection fuel system (HEUI)
- air-to-air aftercooler
- electronically controlled continuously variable temperature-sensing on-demand fan is integrated with electronic engine control module
- cross-flow cylinder head design with three alloy-steel valves per cylinder
- aluminum-alloy skirt and steel crown, 3-ring, 2-piece articulated pistons, cam-ground, tapered and cooled by oil spray
- induction-hardened, forged crankshaft
- deep-skirted cast cylinder block
- tapered connecting rods
- direct-electric 24-volt starting and charging system with two 12-volt, CCA: 750BCI, 475 DIN Caterpillar maintenance-free batteries, heavy-duty starter and a 70-amp alternator
- Electronic Clutch Pressure Control (ECPC) modulates clutch engagement
- single control for both speed and direction
- separate control to lock in neutral
- single-stage, single-phase torque converter
- automatic shift capability
- F-37 high energy friction material provides extended clutch life
- externally mounted controls with quick disconnects for easy diagnostic checks
- high contact ratio gears are precision ground for quieter operation
- thumb operated upshift/downshift rocker switch on Command Control steering version
- quick gear kickdown button included on Conventional steering version
- transmission can be recalibrated using Electronic Technician (ET) service tool
- Variable Shift Control (standard) controlling the selected shift pattern

## Transmission

Electronic planetary power shift transmission with automatic shift capability has four speeds forward and four reverse.

### Maximum travel speeds (standard 23.5-R25 L-3 tires)

Forward	km/h
1	6.9
2	12.7
3	22.3
4	37.0
Reverse	km/h
1	7.4
2	13.7
3	24.0
4	39.5

### Features

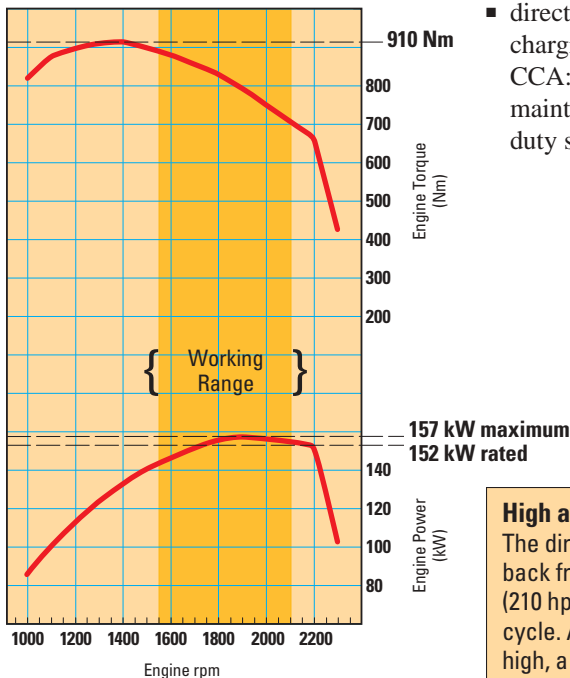

### High available Torque

The direct injected fuel system delivers a controlled increase of fuel as the engine lugs back from rated speed. This results in horsepower greater than rated power. The 157 kW (210 hp) maximum power occurs at 1900 rpm when power is needed during the working cycle. As the maximum torque is close to the working range and the average torque is high, a lot of torque is available during the working cycle. The combination of high available torque and maximum horsepower in the entire working range improves response, provides greater rimpull, more lift force and faster cycle times.

## Axles

Fixed front, oscillating rear ( $\pm 13^\circ$ ).\*

### Features

- maximum single-wheel rise and fall: 470 mm
- differentials, enclosed brakes and final drives included
- conventional differentials are standard; limited slip differentials are optional
- bronze sleeve bearings in the planet gears; bronze sleeve bearings and bronze spherical thrust washers on differential pinions
- patented Duo-Cone seals between axle shaft and housing
- uses SAE 30W (oil change interval: 2000 hours or one year)
- axle oil temperature sensors

\* Oscillating may have to be reduced when using L5 tires, chains or oversized tires.

## Brakes

Meet the following standard: ISO 3450-1996.

### Service brake features

- full-hydraulic actuated, oil-disc brakes
- completely enclosed and sealed
- adjustment free, modulated engagement
- separate circuits for front and rear axles with dedicated piston-type accumulators to ensure dead engine braking
- dual pedal braking system, left-hand brake pedal also integrates a transmission neutralizer and a downshift logic
- external ports provide access to measure brake disc wear.

### Parking brake features

- spring applied, hydraulically actuated, dry drum mounted at midship bearing located in front frame

## Final Drives

Planetary final drives consist of ring gears and planetary carrier assemblies.

### Features

- ring gears are pressed in and doweled to axle housings
- carrier assemblies include:
  - planet gears with free-floating bronze sleeve bearings
  - planet shafts
  - retaining pins
  - bearings
  - sun gear shafts
  - planetary carriers

## Hydraulic System

Open-centered, interrupted series system with full-flow filtering. System is completely sealed.

### Implement system, vane-type pump

Output at 2200 rpm and 6900 kPa with SAE 10W oil at 66°C	292 liters/min
Relief valve setting	20 700 kPa
Cylinders, double acting	
lift, bore and stroke	152.4 x 800 mm
tilt, bore and stroke	177.8 x 540 mm

### Pilot system, vane-type pump

Output at 2200 rpm and 6900 kPa with SAE 10W oil at 66°C	34 liters/min
Working pressure	
pilot	2585 kPa
E/H	3450 kPa

### Hydraulic cycle time

	seconds
Raise	6.3
Dump	2.2
Lower, empty, float down	2.2
Total	10.7

### Features

- completely enclosed system
- low effort, electro-hydraulic controls on Command Control steering version
- low effort, pilot-operated controls on Conventional steering version
- full-flow filtering
- reusable couplings with O-ring face seals
- pilot shutoff valve on Conventional steering or electrical lockout switch on Command Control steering disable implement functions
- swing-out hydraulic oil cooler is standard
- Caterpillar XT hoses
- pressure taps standard
- remote pressure taps available
- automatic Ride Control System is available
- Cat biodegradable oil available

## Cab

Caterpillar cab and Rollover Protective Structure (ROPS) are standard.

### Features

- ROPS meets the following criteria:
  - ISO 3471:1994
- also meets the following criteria for Falling Objects Protective Structure:
  - ISO 3449:1992 LEVEL II
- corrosion-free roof cap

## Linkage Controls

### Lift circuit features

- four positions: raise, hold, lower and float
- in-cab, programmable high and low lift kickouts with cushioned stops on Command Control steering configuration
- mechanically adjustable lift height with automatic kickout on conventional steering configuration

### Tilt circuit features

- three positions: tilt back, hold and dump
- in-cab, programmable kickout for bucket angle load position on Command Control steering configuration
- one mechanically adjustable kickout for bucket angle load position on Conventional Steering configuration

### Controls

- two lever control (standard)
- three lever control (optional)
- joy stick (optional on the conventional steering configuration) combines lift and tilt controls

## Load Sensing Steering

Full hydraulic power steering.  
Meets ISO 5010:1992

### Ratings

Minimum turning radius (over tire)	6027 mm
Steering angle, each direction	40°
Hydraulic output at 2200 rpm and 7000 kPa	160 liters/min
Relief valve setting	19 980 kPa

### Features

- center-point frame articulation
- load sensing hydraulic steering pump
- front and rear wheels track
- flow-amplified, closed-center, pressure-compensated system
- Command Control steering ( $\pm 70^\circ$ ) operates a pilot valve which controls flow to steering cylinders
- Conventional steering wheel ( $\pm 2.7$  turns) operates a hand-metering which controls flow to steering cylinders
- full-flow filtering
- adjustable steering column

## Service Refill Capacities

	Liters
Fuel tank – dry fill	295
Cooling system	49
Crankcase	30
Transmission	34
Differentials and final drives	
Front	36
Rear	36
Hydraulic system (including tank)	153
Hydraulic tank	88

## Sound Levels/Dynamics

Operator sound	dB(A)
Standard sound suppression*	75
Exterior sound	
Standard sound suppression**	109

\* The operator sound pressure levels are measured according to the dynamic test procedures and conditions specified in ISO6396.

\*\* The exterior sound power levels are measured according to the dynamic test procedures and conditions specified in 2000/14/EC.

## Tires

Tubeless, loader-design tires.

- 23.5-R25 XTLA (L-2)
- 23.5-R25 XHA (L-3)
- 625-R25 XLD70 (L-3T)
- 23.5-R25 XLDD2 (L-5)
- 23.5-R25 XMINED2 (L-5)
- 23.5-R25 GP-2B (L-2/L-3)
- 23.5-R25 RL-2+ (L-3T)
- 23.5-R25 GP-4B (L-4)
- 23.5-R25 RL-5K (L-5)

In certain applications (such as load-and-carry work) the loader's productive capabilities might exceed the tires' tonnes-km/h capabilities. Caterpillar recommends that you consult a tire supplier to evaluate all conditions before selecting a tire model.

# Dimensions

All dimensions are approximate

- ◆ Dimensions vary with buckets or tires.  
Refer to operating specifications chart on pages 24-25  
or to supplemental specifications chart on this page.

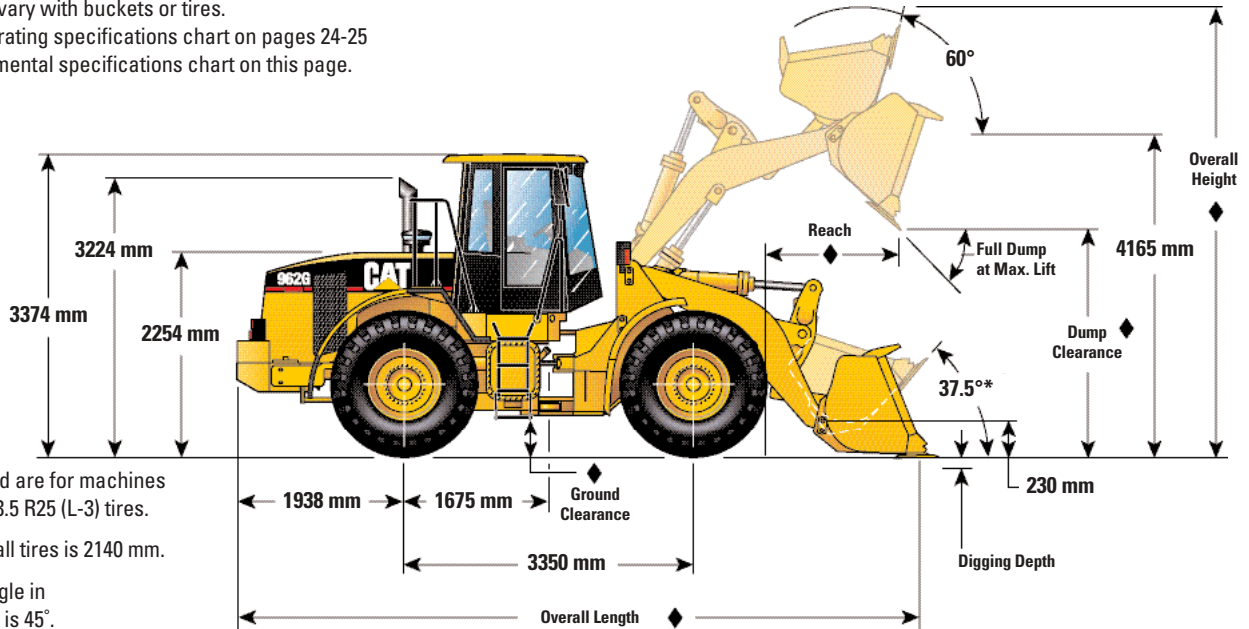

Dimensions listed are for machines equipped with 23.5 R25 (L-3) tires.

Tread width for all tires is 2140 mm.

\* Rack back angle in carry position is 45°.

# Supplemental Specifications

	<b>XHA</b>	<b>XLD70</b>	<b>XLDD2</b>	<b>XMINED2</b>
Tread type	L3	L3T	L5	L5
Dimension	23.5 x R25	625/R25	23.5 x R25	23.5 x R25
Width over tires (mm)	2750	2761	2760	2785
Ground clearance (mm)	405	345	441	464
Change in all vertical dimensions (mm)	Used as reference	-60	+36	+59
Weight variation (kg)	0	-148	+564	+724
Change in static tipping load (kg)				
straight	None	-111	+426	+546
full articulation	None	-99	+375	+482
	<b>GP 2B</b>	<b>RL 2+</b>	<b>GP 4B</b>	<b>RL 5K</b>
Tread type	L2/L3	L3T	L4	L5
Dimension	23.5 x R25	23.5 x R25	23.5 x R25	23.5 x R25
Width over tires (mm)	2760	2763	2774	2771
Ground clearance (mm)	435	433	449	463
Change in all vertical dimensions (mm)	+30	+28	+43	+58
Weight variation (kg)	0	+148	+440	+732
Change in static tipping load (kg)				
straight	None	+112	+332	+552
full articulation	None	+98	+293	+487

# Operation Specifications

		Universal Buckets							
		Bolt-on Cutting Edge	Tips and Segments (no GET)	Bolt-on Cutting Edge	Tips and Segments (no GET)	Bolt-on Cutting Edge	Tips and Segments (no GET)	Bolt-on Cutting Edge	Tips and Segments (no GET)
Rated bucket capacity	m <sup>3</sup>	4.3*	4.3* (4.1)	4	4 (3.8)	3.8	3.8 (3.6)	3.5	3.5 (3.3)
Struck capacity	m <sup>3</sup>	3.9	3.9 (3.7)	3.6	3.6 (3.4)	3.4	3.4 (3.2)	3.1	3.1 (2.9)
Width	mm	2927	2994	2927	2994	2927	2994	2927	2994
Dump clearance at full lift and 45° discharge <sup>4</sup>	mm	2890	2782 (2890)	2918	2816 (3000)	2946	2851 (3035)	2999	2888 (3087)
Reach at full lift and 45° discharge <sup>4</sup>	mm	1307	1400	1260	1364	1214	1328	1161	1251
Reach with lift arms horizontal and bucket level <sup>4</sup>	mm	2880	2880	2830	2972	2780	2922	2705	2847
Digging depth	mm	98	98	98	98	98	98	98	98
Overall length <sup>4</sup>	mm	8365	8365	8315	8457	8265	8407	8190	8332
Overall height with bucket at full raise	mm	5940	5940	5812	5812	5747	5747	5679	5679
Loader turning radius with bucket in carry position	mm	6853	6937	6820	6904	6799	6872	6766	6839
Bucket weight	kg	1940	2026 (1713)	1873	1959 (1646)	1821	1907 (1594)	1846	1932 (1522)
Static tipping load straight <sup>1</sup>	kg	12607	12497 (12930)	12746	12765 (13085)	12900	12731 (13099)	12914	12811 (13293)
Full turn Static tipping load at 37° articulation <sup>1</sup>	kg	10890	10780 (11209)	11020	11019 (11352)	11165	10995 (11358)	11165	11062 (11537)
Breakout force <sup>2</sup>	kN	123.7	122.9 (135.5)	129	127.8 (141.4)	133.6	132.5 (145.8)	141.4	140.7 (156.1)
Operating weight <sup>1</sup>	kg	19259	19345 (19032)	19192	19278 (18965)	19074	19226 (18913)	19165	19251 (18841)

\* Light material only

<sup>1</sup> Static tipping load and operating weight shown are based on average machine configuration with sound-suppression cab and ROPS, secondary steering, air conditioning, ride control, 23.5-R25, L-3, tires, full fuel tank, coolant, lubricants, lights, directional signals with CE plates and operator.

<sup>2</sup> For buckets with adapters, tips and segments, value is measured 100 mm behind the tip of the segment, with bucket hinge pin as pivot point, in accordance with SAE J732C.

<sup>3</sup> All buckets shown can be used on the high lift arrangement. High lift column shows changes in specifications from standard lift to high lift. Add or subtract as indicated to or from specifications given for appropriate bucket to calculate high lift specifications.

**Dimensions for dump clearance, reach and overall length:**

<sup>4</sup> Actual dimensions taken at the tip of the Ground Engaging Tools, either the tip of the bolt-on cutting edge or the tip of the teeth, type long.



		General Excavation Buckets						Rock Buckets				High Lift <sup>3</sup>
Bolt-on Cutting Edge	Tips and Segments (no GET)	Bolt-on Cutting Edge	Tips and Segments (no GET)	Bolt-on Cutting Edge	Tips and Segments (no GET)	Bolt-on Cutting Edge	Tips and Segments (no GET)	Bolt-on Cutting Edge	Tips and Segments (no GET)	Bolt-on Cutting Edge	Tips and Segments (no GET)	
3.3	3.3 (3.1)	3.3	3.3 (3.1)	3.1	3.1 (2.9)	2.9	2.9 (2.7)	3.3	3.3	2.9	2.9	same
2.9	2.9 (2.7)	2.8	2.8 (2.6)	2.7	2.7 (2.5)	2.5	2.5 (2.3)	3	3	2.6	2.6	same
2927	2994	2927	2994	2927	2994	2927	2994	2984	2969	2984	2969	same
3034	2938 (3122)	3057	2969 (3141)	3080	2992 (3164)	3119	3030 (3202)	3034	3025	3086	2977	+308
1125	1238	1246	1365	1219	1338	1174	1292	1350	1360	1284	1421	+52
2655	2797	2705	2847	2670	2812	2610	2752	2789	2802	2705	2718	+266
98	98	98	98	98	98	98	98	98	117	98	117	-10
8140	8282	8190	8332	8155	8297	8095	8237	8274	8287	8190	8203	+326
5632	5632	5705	5705	5640	5640	5583	5583	5679	5679	5590	5590	+374
6745	6818	6770	6843	6749	6822	6728	6801	6847	6920	6808	6881	+267
1705	1791 (1658)	1828	1914 (1601)	1774	1860 (1547)	1706	1792 (1479)	2047	2125	1892	2070	-
13139	13037 (13425)	12563	12462 (12829)	12914	12813 (12934)	12815	12718 (13089)	12568	12424	12767	12644	-1070
11382	11279 (11660)	11084	10981 (11349)	10959	10860 (11225)	11104	11006 (11370)	10845	10707	11035	10908	-985
148.4	147.7 (163.8)	141.93	141.3 (156.1)	146.68	160.6 (161.6)	154.9	154.3 (171.5)	133.4	128	143.3	140.3	-7
19024	19110 (18797)	19147	19233 (18920)	19093	19179 (18866)	19025	19111 (18798)	19366	19444	19211	19389	+460

## Bucket Selection Guide

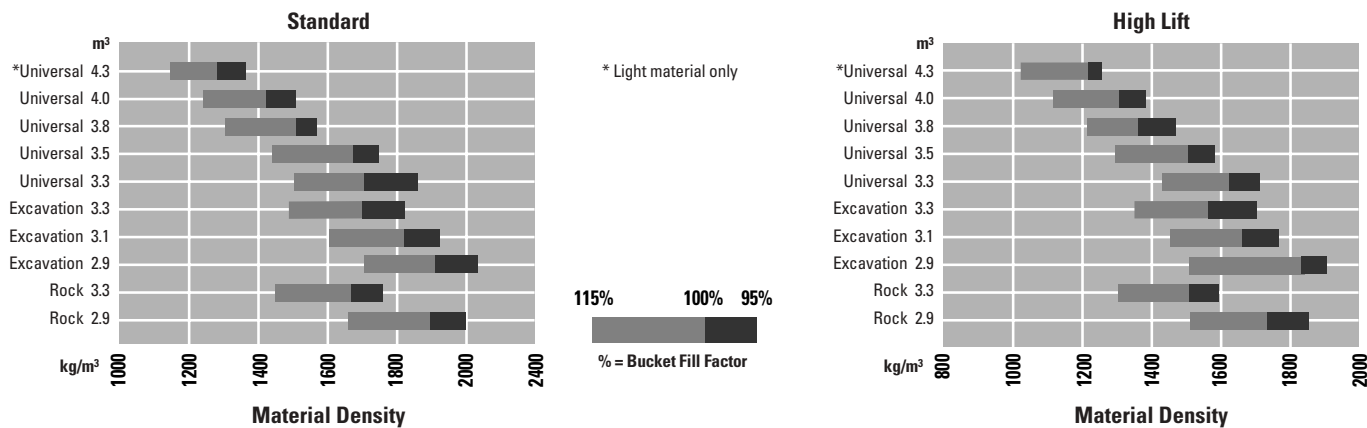

Note: In accordance with SAE J818, these data consider the bucket load to be equal to half of the static tipping load at full turn.

# Standard Equipment

Standard equipment may vary. Consult your Caterpillar dealer for specifics.

## Electrical

70-amp alternator  
Batteries (two 12-volt, maintenance free,  
CCA: 750 BCI, 475 DIN)  
Ignition key start/stop switch  
Main disconnect switch  
Light directional signals\*\*  
Starter, electric, heavy duty (24-volt)  
Voltage converter (12-volt, 5 amp)  
Diagnostic connector  
Working halogen lighting system,  
including six lights:  
Two forward floodlights on  
the front frame  
Two forward floodlights on the cab  
Two rearward floodlights on  
the counterweight

## Starting Aid

Ether starting aid\*\*

## Operator Environment

Air conditioning (R134a refrigerant)\*\*  
Adjustable steering column  
Conventional steering version:  
Seat with mechanical suspension,  
adjustable backrest, armrest and  
lumbar support  
Storage compartment for  
personal items  
Pilot hydraulic implement controls,  
lift and tilt  
Hydraulic lift and tilt lock lever  
Command Control steering version:  
Caterpillar Contour Series seat, 6-way  
adjustable, with air suspension  
Electro-hydraulic implement controls,  
lift and tilt  
Programmable and cushioned lift/tilt  
kickouts  
Hydraulic lift and tilt lock switch  
Cab, pressurized with sound suppression  
and rollover protective structure (ROPS)  
Cab dome lights\*  
Heater and defroster\*  
Horn, electric  
Cigar lighter and ashtray  
Coat hooks (2)  
Cup and thermos holders  
Mirrors, rearview, outside mounted  
Radio ready cab\*

Seat belt, retractable, 76 mm wide  
Tinted glass  
Sun visor  
Electronic monitoring system:  
3-category alarm system  
Gauges:  
Speedometer  
Tachometer  
Fuel level  
Hydraulic oil temperature  
Transmission oil temperature  
Engine coolant temperature  
Warning indicators:  
Engine oil pressure  
Parking brake  
Axle oil pressure  
Electrical system  
Engine inlet manifold temperature  
Brake oil temperature  
Hydraulic oil level  
Hydraulic filter bypass  
Primary steering oil pressure  
Secondary steering oil pressure\*\*  
Windshield washers/wipers, wet arm,  
front and rear, front intermittent\*

## Engine

Cat 3126B ATAAC diesel engine,  
HEUI, turbocharged with air-to-air  
aftercooler  
Cooling system:  
Multi-row modular radiator  
On demand radiator cooling fan,  
hydraulically driven  
Hydraulic oil cooler  
Air conditioner condenser\*\*  
Fuel system Priming pump, electric  
Air precleaner, Radial Seal filters,  
primary (Ultra High Efficiency)  
and secondary  
Sound suppressed muffler

## Drive Train

Torque converter  
Transmission, planetary, power  
shift, 4F/4R:  
Electronic Clutch Pressure Control  
Automatic shift capability  
Fully automatic speed range control  
Direction and gear selection switch with  
quick gear kickdown button

Transmission diagnostic connectors  
(pressure taps)  
Transmission auto/manual switch  
Transmission neutralizer on/off switch  
Brakes, full-hydraulic actuated,  
enclosed wet discs  
Differential limited slip, rear axle\*\*  
Integrated Braking System  
Variable Shift Control

## Hydraulics

Automatic bucket positioner  
Automatic Ride Control System\*\*  
Caterpillar O-ring face seals couplings  
Caterpillar XT hoses  
Loader linkage, sealed Z-bar design  
Steering, load-sensing hydraulic  
Secondary steering\*\*

## Preventive Maintenance

Caterpillar High Efficiency fuel filters  
Caterpillar Ultra High Efficiency,  
Radial Seal primary air filter  
Caterpillar Radial Seal secondary  
air filter  
Extended Life Coolant  
antifreeze (-30°C)  
Hydraulic pressure taps  
(diagnostic connectors)  
Product Link ready  
Scheduled Oil Sampling (S•O•S) valves  
Service indicators:  
Engine air filter restricted in-cab indicator  
Coolant level sight gauge  
Hydraulic oil level sight gauge  
Transmission oil level sight gauge

## Other Standard Equipment

Counterweight, single section  
Drawbar hitch with pin  
Crankcase guard  
Ecology drains for engine, transmission,  
hydraulics.  
Engine enclosure, tilting, electrically  
actuated, non-metallic, one-piece  
Fenders, front, with mud flaps  
Platform deflectors for rear wheels  
Locking engine enclosures  
Vandalism protection, caplocks\*\*  
Powertrain guard\*\*

\* Not included in Open Cab configuration

\*\* May be optional in some countries

# Optional Equipment

Optional equipment may vary. Consult your Caterpillar dealer for specifics.

## Electrical

Auxiliary halogen lighting package including

- Two additional forward floodlights on the cab
- Two rearward floodlights on the cab

Back up alarm

Roading light package, including turning signals, high/low beams and associated switch

Warning lighting system, rotating beacon

## Starting Aid

Heater, engine coolant, 220 V

## Operator Environment

On the Conventional steering version,

- Caterpillar Contour Series seat, 6-way adjustable, with air suspension

Rearview mirrors, interior

Sliding window on right-hand side

Lift lever F-N-R switch

## Drive Train

Axle oil cooler

Free wheel stater torque converter

Differential Limited Slip, front axle

Differential No SPIN, rear axle

## Hydraulic

Hydraulic arrangement, third valve

## Preventive Maintenance

Automatic central lubrication system (factory installed)

Extended Life Coolant antifreeze (-35 to -50°C)

Cat Turbine PreCleaner

Product Link

Remote diagnostic pressure taps for hydraulic and transmission systems

## Environmental Attachments

Cat Bio Hydo (HEES), biodegradable hydraulic synthetic ester based oil

Ecology drain, axle

## Other Optional Attachments

Buckets (see pages 14-15)

Other Work Tools (see page 17)

Dedicated quick coupler actuation circuit

High Lift arrangement

High Lift arrangement with hydraulic third valve

Open cab, including ROPS structure (for conventional steering only)

Payload Control System

Rear full coverage roading fenders, swingable, non-metallic

Fast fill engine oil

## Anti-Corrosion Arrangement

providing extensive protection to vital machine components and other surfaces in harsh corrosive applications.

## Forestry Arrangement

keeping your millyard operation efficient and productive at every stage.

## Waste Handling Arrangement

providing extensive guarding and machine modifications (e.g. trash grill), yet allowing easy access for cleaning and maintenance.

# 962G Series II Wheel Loader

HEHL2725 (12/2001) hr

Materials and specifications are subject to change without notice.  
Featured machines in photos may include additional equipment.  
See your Caterpillar dealer for available options.

[www.CAT.com](http://www.CAT.com)  
© 2001 Caterpillar

**CATERPILLAR**<sup>®</sup>