



YANMAR

WHEEL LOADER

V3-6

V4-6



Dynamism and Usability

V3/V4-6 has accomplished greater efficiency & comfort for the powerful operation with its greatly increased operation load.

The features such as new design of working lights including turning signals, large footsteps and clear instrument panel are improved for operator's usability.

Easy and unrestricted operating space offers greater visibility with comfortable suspension seat that reduces operating stress and fatigue.

Easy Maintenance and Clean & Silent Engine

Easy and simple access to the power line (From Engine to Transmission) brings big improvements to maintenance efficiency by easy opening rear bonnet and removal floorboard.

The large cast iron counter-weight securely protects the working lights and provides the best stability during loader works.

Equipped Clean & Silent Yanmar Diesel Engine, in full compliance with I-Tire4 EPA(USA) and stage III A EC(EU) regulations.

WHEEL LOADER

V3-6

V4-6

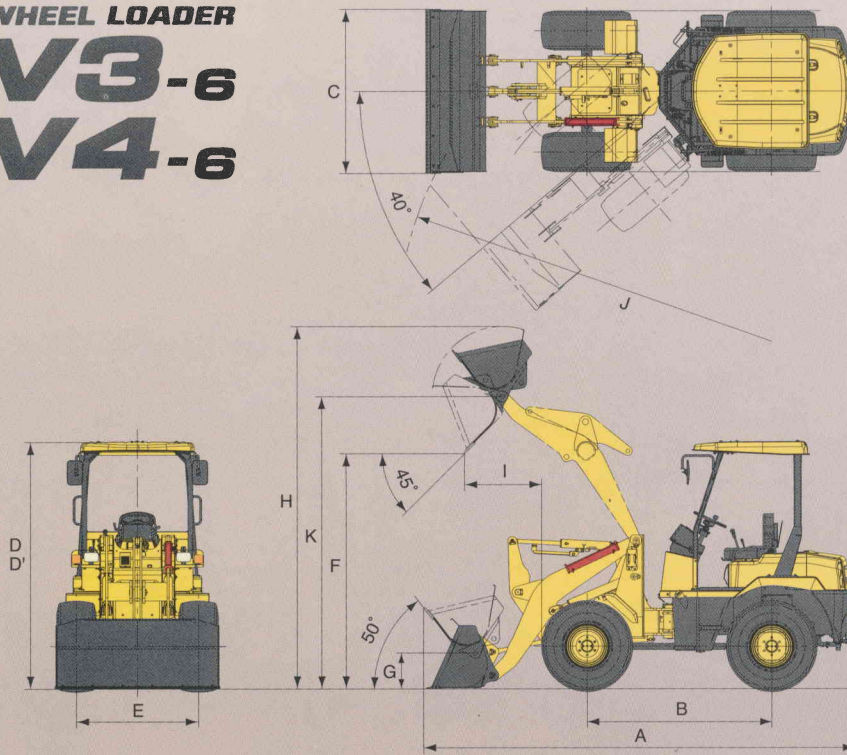

Dimensions

unit:ft-in(mm)

	V3-6	V4-6
A	13'2"(4015)	14'5"(4400)
B	5'9"(1750)	6'3"(1900)
C	5'2"(1570)	5'7"(1690)
D	8'1"(2475)	8'5"(2560)
D'	8'0"(2435)	8'3"(2520)
E	3'11"(1180)	4'1"(1240)
F	7'0"(2130)	7'11"(2420)
G	10"(260)	1'0"(300)
H	10'11"(3340)	12'3"(3730)
I	2'7"(780)	2'7"(790)
J	11'9"(3585)	12'9"(3875)
K	8'9"(2670)	9'11"(3010)

D : Canopy specifications
D' : Cabin specifications

Specifications

MODEL		V3-6	V4-6	
ENGINE	Type	water-cooled 3-cyl. diesel		
	Model	3TNV88-BNKAH		
	Output	HP(kW)/min ⁻¹ 30.3(22.6) /2500		
	Displacement	cu.in(ft) 100.2 (1.642)		
PERFORMANCE	Std. bucket capacity	cu.yd(m ³) 0.52 (0.4)		
	Operating load	lb(kN) 1962 (8.7)		
	Lifting capacity at low end	lb(kN) 5760 (25.6)		
	Tipping load	straight	lb(kN) 4785 (21.3)	
		full turn	lb(kN) 3924 (17.4)	
	Breakout force	lb(kN) 5400 (24.0)		
	Dumping clearance	ft-in(mm) 7'0" (2130)		
	Traveling speed	mph(km/h) 11.8 (19.0)		
	Oscillation angle	degree ±8		
Min.turning radius	ft-in(mm) 11'9" (3585)			
Min.ground clearance	ft-in(mm) 10" (260)			
PTO	Front Hyd.PTO	PSI(kPa) 3000(20590)		
		GPM(L/min) 10.7 (40.5)		
STEERING	Type	Center-pivot frame articulation with full hyd. power		
	Articulate angle	degree 40		
TRANSMISSION	Type	Automatic hydrostatic		
DRIVES	Type	4-wheel drive		
WHEELS	Type	12.5/70-16-6PR	15.5/60-18-8PR	
BRAKES	Type	Fully enclosed, mechanical, wet, multiple disc		
OPERATING WEIGHT	Canopy	lb(kg) 6801 (3085)		
	Cabin	lb(kg) 7154 (3245)		
TRANSPORT. DIMENSIONS	L×W×H	ft-in 13'2"×5'2"×8'1"		
		mm 4015×1570×2475		
		4400×1690×2560		

Note: All information presented in this Brochure is subject to change without notice.

YANMAR AMERICA CORP.

CONSTRUCTION EQUIPMENT DEPT.
101 International Parkway, Adairsville, GA 30103, U.S.A.
TEL:770-877-7570 FAX:770-877-7572
<http://www.yanmar.com>

Les Équipements Achard Ltée
3175, boul. du Royaume
Jonquière (Québec) G7X 7V3
Tél. : (418) 548-7182

Printed in USA
000060E2816 0802