

normet

Normet Oy
Ahmolantie 6
FI-74510 IISALMI, FINLAND
Tel +358 (0) 17 83 241
Fax +358 (0) 17 823 606
info@normet.fi www.normet.fi

Spraymec 6050 WP

TI 100004455
DATE 04.01.2013
PAGE 1 / 4

Diesel-hydraulic Shotcreter

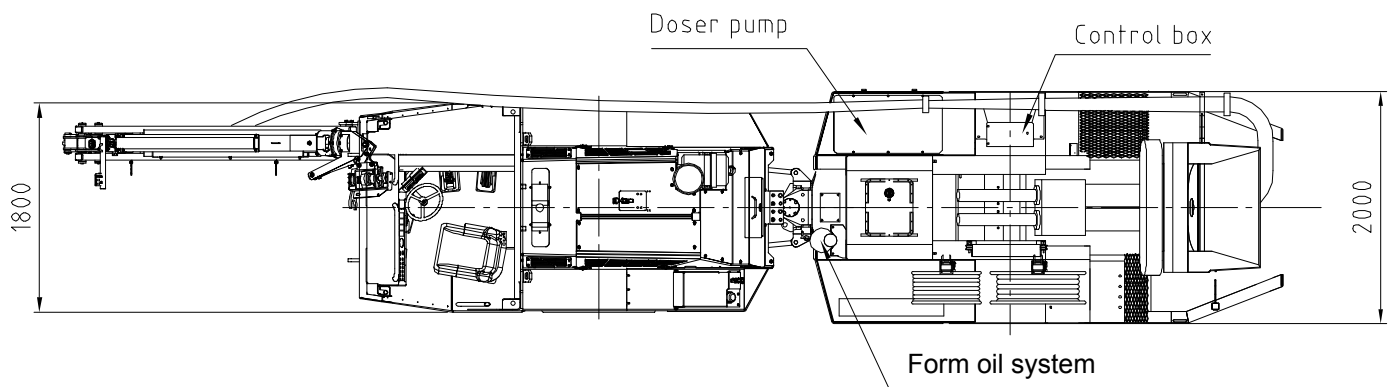
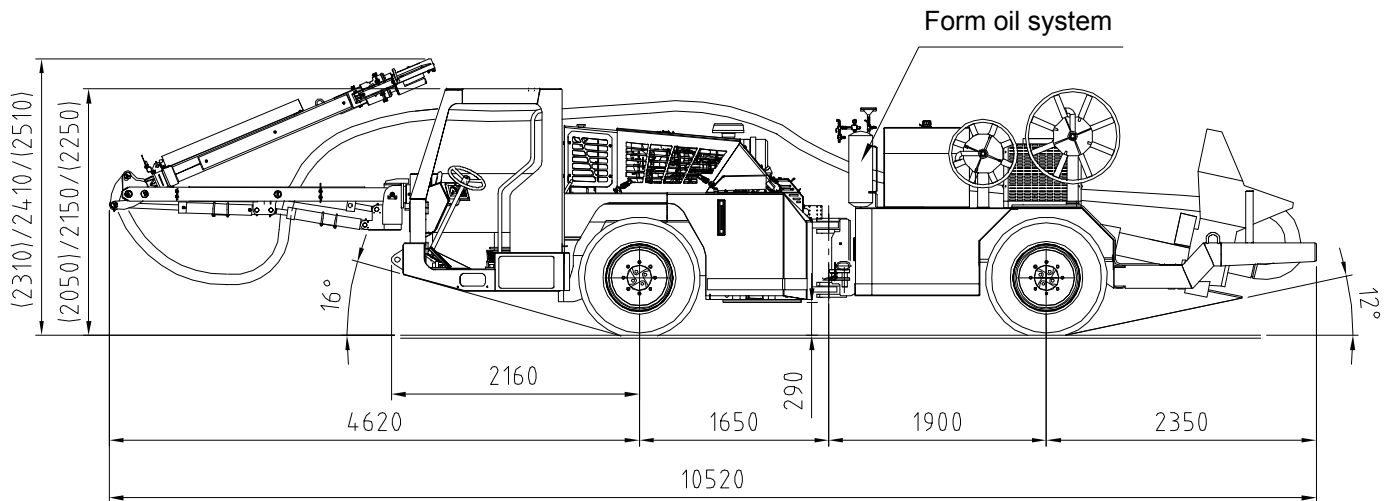

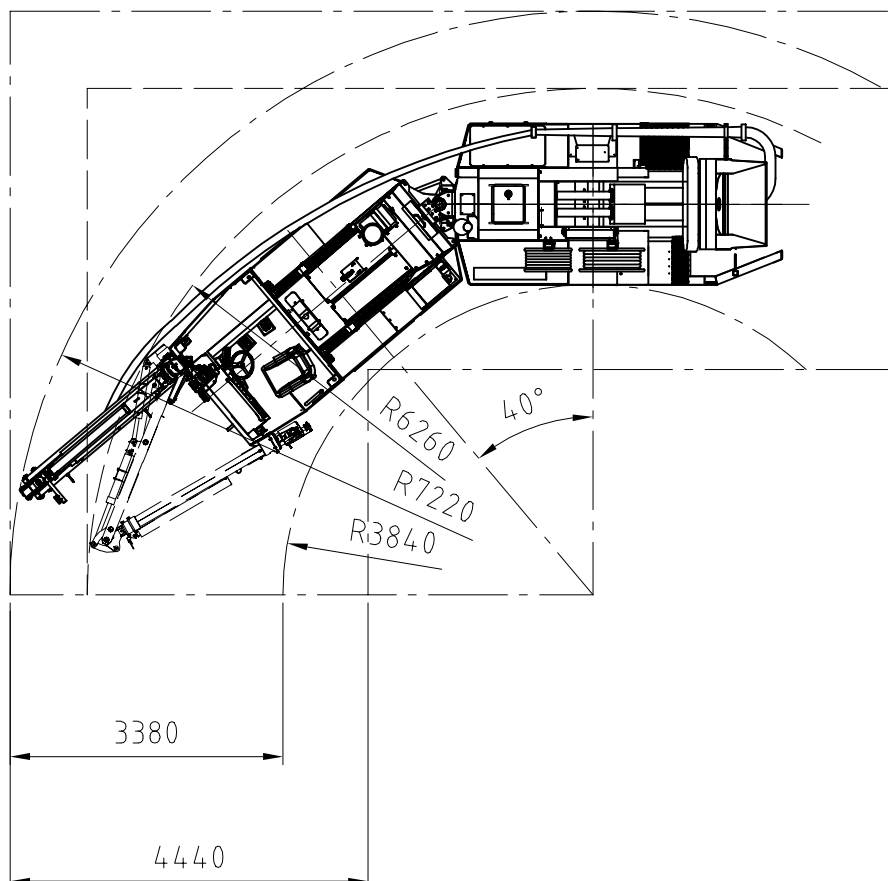
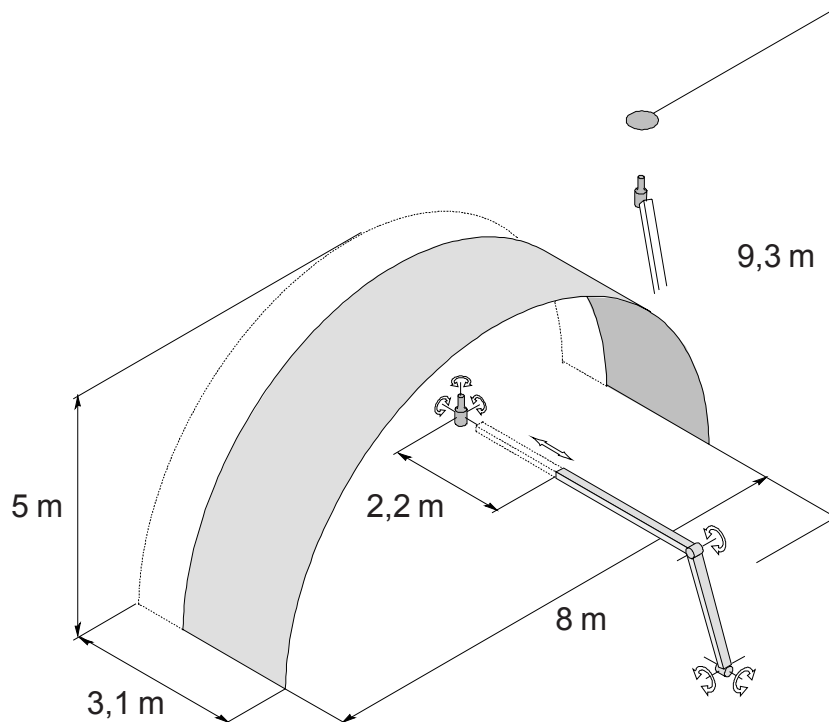

ENGINEDeutz TCD 2012
96 kW/2200 rpm**TRANSMISSION**Dana powershift
3 speeds forward and reverse
4-wheel drive**AXLES**

Planetary type

TYRES

10.00 - 20 PR 16

BRAKES**Drive brake:** hydraulic power assisted dual-circuit
oil immersed multidisc brakes in both axles
Safety/Parking brake: hydraulically released
fail safe -type brake**STEERING**Hydraulic frame steering
Orbitrol type
Frame articulation +/- 40°
Oscillation +/- 10°**HYDRAULICS**Steering and boom
210 bar, 95 L/min/2200 rpm**ELECTRICAL SYSTEM****Carrier:**24 V
Battery 2 x 105 Ah
Alternator 80 A
Lights (2+2) x 70 W**Shotcreting operations:**

Working lights 6 X 70 W

PERFORMANCE CURVE3700350
1st. gear max. 5 km/h
2nd gear 14 km/h
3rd gear 30 km/h
Max. tractive effort 90 kN**DIMENSIONS**Length 10520 mm
Width 2000 mm
Height 2150 mm
Wheel base 3550 mm
Track 1480 mm
Ground clearance 290 mm**TURNING RADIUS**Outer 7220 mm
Inner 3840 mm**WEIGHT**

Operating 13500 kg

SHOTCRETING BOOMBoom rotation 270°
Boom lifting -20°...+75°
Boom folding -60°...+165°
Extension 2200 mm
Nozzle rotation 360°
Nozzle tilting 105°**WET CONCRETE PUMP**Diesel hydraulic 4-19 m³/h**ACCELERATOR PUMP**Max. pressure 20 bar
Liquid flow 1...20 L/min**ACCELERATOR TANK**

Volume 350 L

AIR HOSE REEL

Manual, 1 1/2" hose 30 m

WATER HOSE REEL

Manual, 3/4" hose 30 m

OPEN CABIN

ROPS/FOPS Approved

OPTIONAL EQUIPMENT:

Mercedes-Benz OM 904 LA 90 kW engine
LED driving lights (4 + 2 pcs)
LED working lights on cabin (2 + 2 pcs)
Upgrade Nordozer 900 EH
SB 500 radio remote control

ADDITIONAL EQUIPMENT:

Hydraulic driven high pressure washer 180 bar / 30 L
Rock wall washing system 460 bar / 50L
Fogmaker extinguishing system (manual)
Fogmaker extinguishing system (automatic)
Ansul extinguishing system (manual)
Ansul extinguishing system (automatic)
Tempus manually actuated (Non CE)
Lubrication system for carrier, boom and pump
(Lincoln)
Fast fuel filling system: Wiggins
1 extra hand held fire extinguisher (12 kg)
1 extra rotating beacon amber
1 extra rotating beacon red
1 extra rotating beacon blue
1 extra strobe light white
Tools for maintenance
Reversing camera
NT60 spare wheel
Form oil system
Front support legs
Text labels in:
Fin/Por/GB/Swe/Rus/Nor/Ger/Fra/Spa/Ita

LTC SERVICES:**SPARE PARTS**

Spare parts package A: Available for 1000 h of use*.
Include periodical service, most common wearing parts
and most critical safety parts.

Spare parts package B: Available for 3000 h of use*.
Include periodical service, most common wearing parts
and most critical safety parts.

* Recommendations are based on average
hours - can vary a lot depending on work site
conditions.

TRAINING SERVICES

Available before delivery, at start up and after
delivery

Product training:

Operation and Maintenance
NorSmart
Foundation of electrics, hydraulics
and mechanics
Audit

Process training:

Concrete spraying
Charging
Process audit

AUDIT SERVICES

To improve performance of the machines
To improve the performance of your processes
To help improve the quality of maintenance operations

SERVICE CONTRACTS

Spare parts supply programmes
Scheduled inspection programmes
Supervision programmes
Periodic maintenance programmes
Machine usage programmes

LINK ONE

Link One electronic spare part manuals

WARRANTY SERVICES

Extended warranty