

APPLICATION

The Sandvik DD420-40 is a two boom electro hydraulic jumbo for fast and accurate drilling in drifting and tunneling of 8 – 49 m² cross sections.

The hydraulic controlled drilling system with added automatic functions and different optional instrumentation levels enable productive and high quality excavation. Built-in diagnostics help to minimize maintenance time.

The HLX5 rock drills deliver superior performance with high consumable life.

The TB 40 universal booms have a large optimum shaped coverage and full automatic parallelism. The booms can also be used for cross-cutting and bolt hole drilling.

The powerful 4-wheel-drive center articulated carrier ensures rapid and safe tramming with good balance.

MAIN SPECIFICATIONS

Carrier	1 x TC 7
Safety canopy	1 x FOPS (ISO 3449)
Rock drill	2 x HLX5
Feed	2 x TF 500-12
Boom	2 x TB 40
Control panel	2 x THC 560
Powerpack	2 x HP 560 (55,0 kW)
Air compressor	1 x CT 10 (7,5 kW)
Shank lubricating device	1 x SLU 2
Water pump	1 x WBP 2 (4,0 kW)
Main switch	1 x MSE 20
Cable reel	1 x TCR 3E
Length	12 550 mm
Width	1 980 mm
Height	
Canopy down	2 350 mm
Canopy up	3 200 mm
Weight	21 400 kg
Tramming speed	
Horizontal	16,0 km/h
14 % = 1:7 = 8°	6,5 km/h
Gradeability	28 % = 1:3,5 = 15°
Noise level (EN 791, free field condition)	
Operator's platform	LpA = 102 dB
Emitted	LwA = 124 dB

GENERAL DIMENSIONS

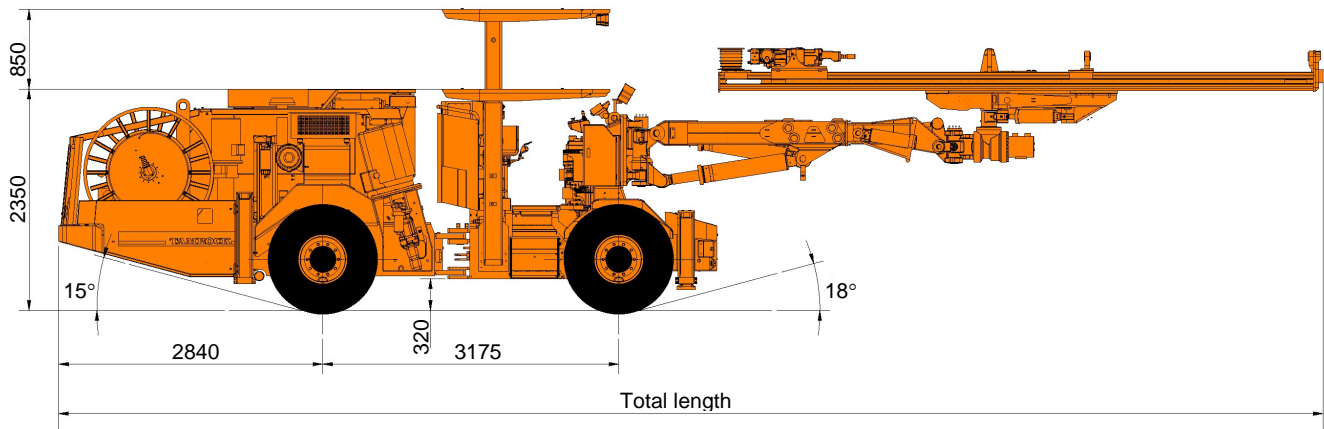

Feed	Total length	Total length (with TRR 1)
TF 500-10'	12 000	12 035
TF 500-12'	12 550	12 585
TF 500-14'	12 750	12 785
TF 500-16'	13 200	13 235

TC 7 CARRIER

Diesel engine	MB OM904LA 110 kW (149 hp)
Transmission	Clark 20 000 Hydrodynamic
Axles	Spicer
Brakes	
Service	Hydraulically operated wet disc brakes
Parking and emergency	SAHR type, fail-safe wet disc brakes
Tyres	12.00 - 20 PR 20
Steering	Frame steering, Orbitrol
Articulation	± 40°
Rear oscillation	± 10°
Ground clearance	320 mm
Fuel tank	150 l
Hydraulic jacks	
Front	2 x TJ 40
Rear	2 x TJ 60
Safety canopy	FOPS (ISO 3449)

HLX5 ROCK DRILL

Weight	210 kg
Length	955 mm
Profile height	87 mm
Power class	20 kW
Max working pressure	
Percussion	225 bar
Rotation	175 bar
Max torque	
80 cm ³ motor	400 Nm
Hole size	43 - 64 mm
Recommended steel	T38-H35-R32 T38-H35-alpha 330 T38-R39-R35
Shank adapter	7304-7585-01 (T38)
Flushing water pressure	10 - 20 bar

TF 500 FEED

Feed type	Cylinder - wire rope
Feed force	25 kN

FEED TF 500-	Total length (mm)	Hole length (mm)	Rod length (mm)	Net weight (kg)
10'	4 660	2 830	3 090	470
12'	5 270	3 440	3 700	500
14'	5 880	4 050	4 305	530
16'	6 490	4 660	4 915	560

TURNING RADIUS

FEED	R1	R2
TF 500-10'	6 200	3 200
TF 500-12'	6 300	3 200
TF 500-14'	6 450	3 200
TF 500-16'	6 600	3 200

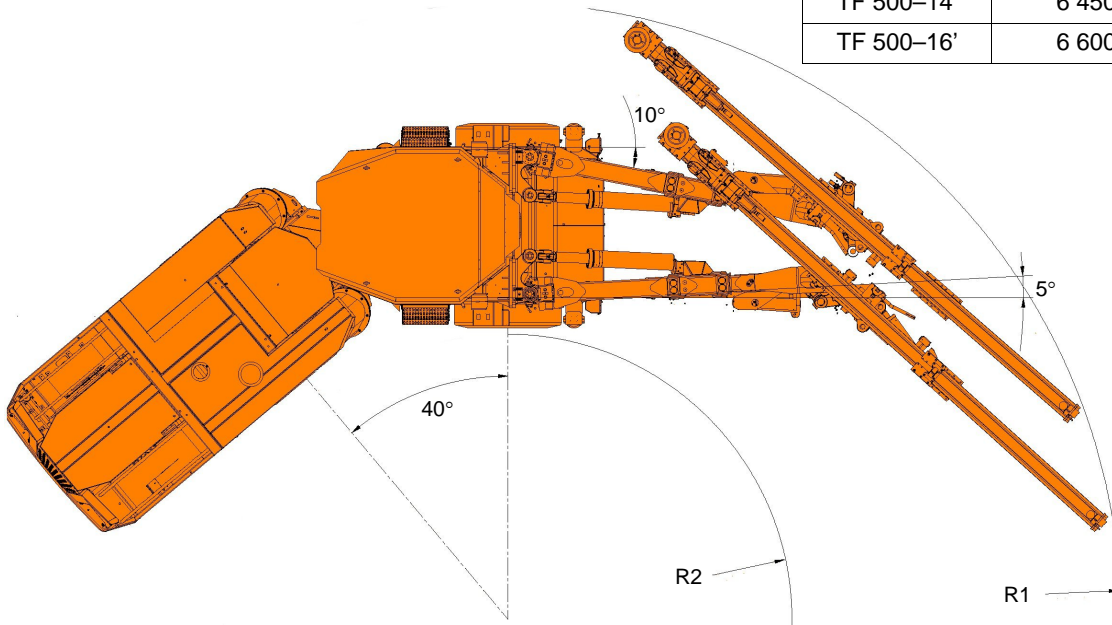

TB 40 BOOM

Parallel coverage	44,5 m ²
Boom extension	1 050 mm
Feed extension	
With TF-feed	1 350 mm
Boom weight, net	1 850 kg
Rotation angle	358°

THC 560 CONTROL SYSTEM

Power control	Adjustable full power Adjustable collaring power
Rotation control	Adjustable rotation speed
Automatic functions	Collaring Feed controlled percussion Anti-jamming Flushing Stop and return
Boom controls	Fully proportional

HP 560 POWERPACK

Electric motor	1 x 55 kW 3-phase motor
Pump types	
Percussion, feed and boom	1 x 145 l/min variable displacement axial piston pump
Rotation	1 x 46 l/min gear pump
Filtration	
Pressure	1 x 20 micron
Return	1 x 12 micron
Oil tank volume	Max. 235 l, min. 135 l
Tank filling	1 x manual pump
Oil cooling	1 x OW 30 water cooler

AIR CIRCUIT

Compressor type	1 x CT 10 (7,5 kW)
Capacity	1,0 m ³ /min, 7 bar
Shank lubricating device	1 x SLU 2
Air consumption	250 – 350 l/min / rock drill
Oil consumption	180 – 250 g/h / rock drill

WATER CIRCUIT

Water pump type	1 x WBP 2 (4,0 kW)
Capacity	100 l/min (15 bar) With 5 bar inlet pressure
Inlet pressure	2 – 7 bar (while drilling)
Inlet pressure control valve	1 x WP 70

ELECTRICAL SYSTEM

Total input power	135 kW
Main switch	1 x MSE 20
Standard voltages	380 – 690 VAC
Voltage fluctuation	Max. ± 10 %
Lighting	
Working lights (24 VDC)	4 x 35 W (HID) front 2 x 70 W rear
Driving lights (24 VDC)	2 x 35 W (HID) front 4 x 70 W rear
Automatic cable reel	1 x TCR 3E

COVERAGE AREA

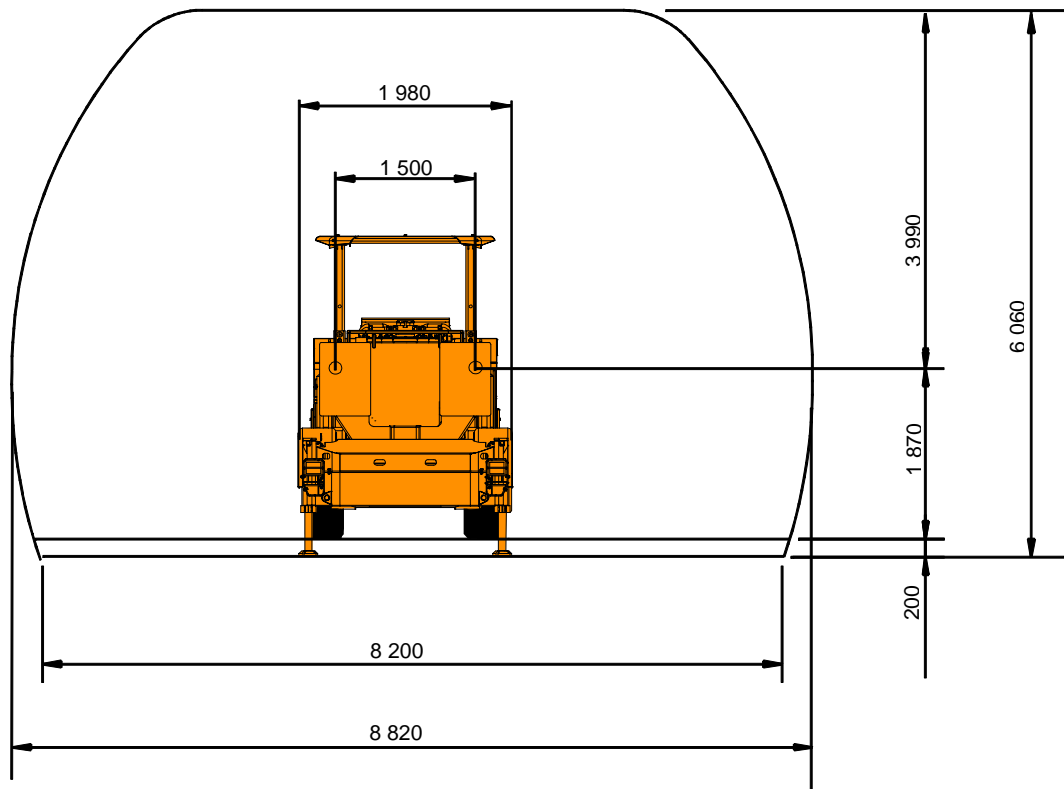

OPTIONAL EQUIPMENT

DRILLING SYSTEM

- *) HL 510S-45 rock drills
- *) Feed length 10', 14' or 16'
- *) Telescopic feed TFX-series
- Rod retainer TRR1 for one feed
- TRS two-rod system for one boom (includes TRR1)
- Drill angle measuring instrument TMS D2
- Drill angle and depth measuring instrument TMS DDSS2
- Drill position and angle measuring instrument TCAD-DS
- Data logging unit TLOG for TCAD
- *) Double flushing with CT 16 compressor (11,0 kW)
- Air mist flushing kit for auxiliary water/air connection
- Flushing flow control

ELECTRICAL SYSTEM

- Electric cable rubber or PUR
- Ground fault and overcurrent unit VYK
- *) 1 000 VAC electric system
- Star-Delta starting (380 – 690 VAC only)
- Extra working lights 2 x 35 W (24 VDC) HID

CARRIER

- Exhaust scrubber
- Exhaust catalyzer
- Complete spare wheel

OTHER OPTIONAL EQUIPMENT

- Fire extinguisher (bottle only)
- Manual fire suppression system ANSUL, 6 nozzles
- Pressure cleaning system (15 bar) with reel
- Automatic water hose reel THR 2.5E
- Water hose 1 ½"
- *) Electric filling pump for hydraulic oil
- Greasing reel with pump and nozzle
- Automatic greasing system (Lincoln)
- Biodegradable oils
- Air cleaner IP 5 with connections
- Fast filling and evacuation system Wiggins for fuel
- Fast filling and evacuation system Wiggins for fuel, transmission, engine and hydraulic oil
- *) EU, UL, CSA, AUS norms package

*) = Replaces standard component

Sandvik Mining and Construction reserves the right to change this specification without further notice.