

APPLICATION

Commando 300 is a hydraulic, self-propelled drilling unit on a 4-wheel, oscillated drive carrier. It drills holes with a maximum recommended diameter of 64 mm (2 1/2") and a maximum practical length of 15 meters (50'), utilizing 25, 28 or 32 mm (1", 1 1/8" or 1 1/4") extension rods.

Commando 300 is a completely self contained drilling unit. It is easily maneuverable with good rough terrain capabilities. It is also easy to transport between job sites on a truck or on a trailer, or it can even be lifted by a helicopter.

Commando 300 is equipped with HL 300, hydraulic top hammer rock drill. The rock drill is mounted on an aluminium chain feed, which is attached to an articulated boom giving a drilling coverage of 10 m² (108 sq-ft). A 55 kW (73 hp) diesel engine supplies power both for hydraulic pumps and for an on-board compressor. Several routine functions of Commando 300, e.g. collaring and antijamming, are automatically executed by electronic controls.

For easy operation, good visibility and operator safety, Commando 300 is supplied with an electronic remote control unit. Thanks to the electronics, this unit has fewer levers which make it easy to use. For operator comfort Commando 300 is also equipped with a dust collection system, which gathers drilling dust from the hole into a plastic bag.

Typical applications for Commando 300 are foundation drilling, road cutting, trenching, occasional bolting and other special drilling applications. Therefore Commando 300 is most often used by construction contractors, mines and quarries, and the municipal sector. Due to its versatility Commando 300 is often included in the equipment fleet of rental houses as well.

COVERAGE AREA

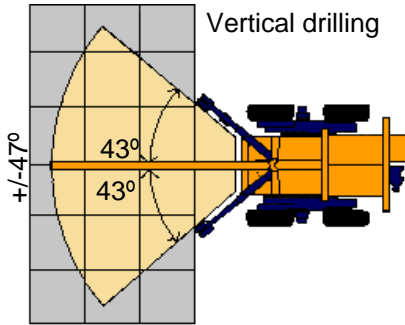
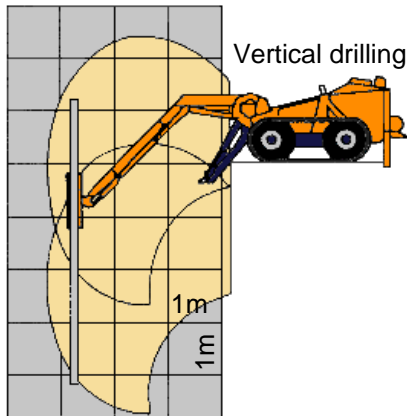

Horizontal drilling, forwards
 With manual roll-over

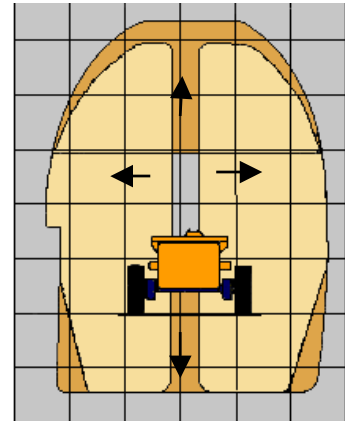

Horizontal drilling, sideways

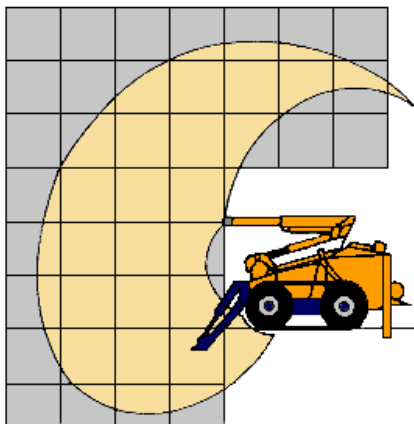

Bolting

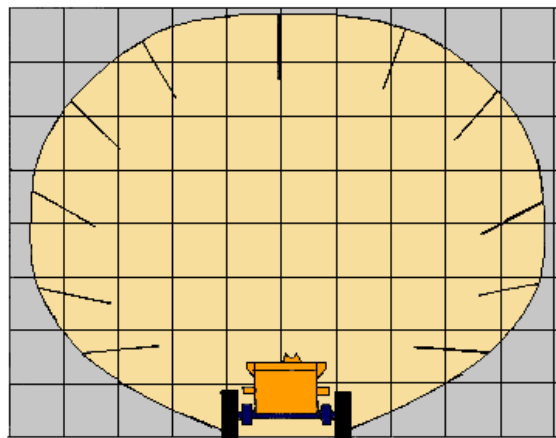

DIMENSIONS

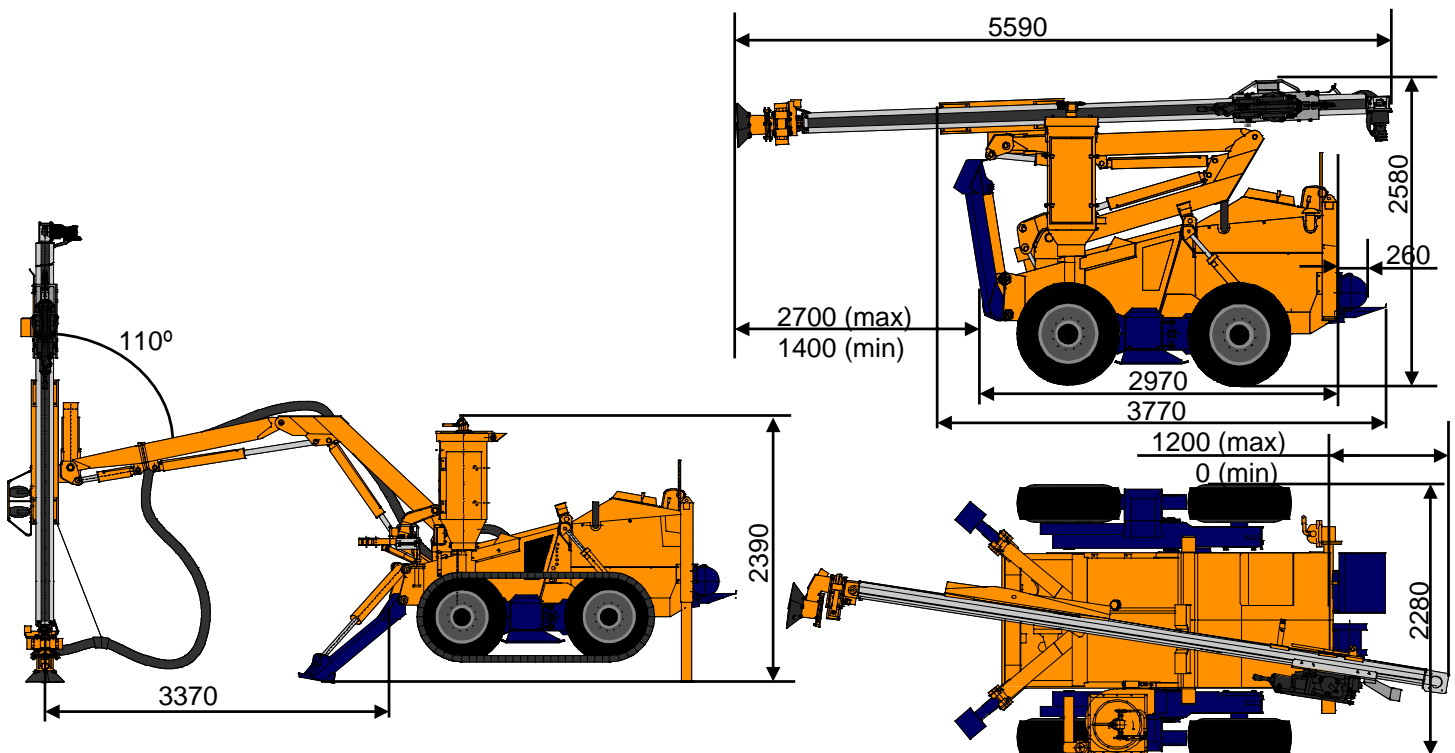

STANDARD COMPONENTS

- | | | |
|-----|------------------------|--|
| 1. | Rock drill | HL 300, hydraulic |
| 2. | Chain feed | CF 300 x 12/Pito 9H, incl. one set of jaws |
| 3. | Rod rack | For 2 extra rods on chain feed |
| 4. | Boom | DB 300, articulated |
| 5. | Carrier | Rubber-tyred |
| 6. | Powerpack | Diesel driven, hydraulic pumps and on-board compressor |
| 7. | Hydraulic system | Open center and load sensing |
| 8. | Control system | TA 342, electric |
| 9. | Dust collection system | DC 410H, hydraulic |
| 10. | Working lights | 4 pcs |
| 11. | Hydraulic jacks | 4 pcs |
| 12. | Manuals | Service and spare parts manuals:
2 x paper copy
2 x CD-ROM (Toolman) |
| 13. | EU-safety devices | |

TRANSPORT DIMENSIONS

Weight (without options)	5 000 kg
Width without tracks	2.3 m
Height	2.6 m
Total length	5.6 m

THE JAWS FOR DRILL STEELS

	Drill steel type	Drill steel diameter	Recommended hole diameter
1.	Integral rod for HEX 1 drifter	22 mm $7/8"$	28 - 38 mm $1\ 7/64" - 1\ 1/2"$
2.	Extension rods	25 mm 1"	38 - 45 mm $1\ 1/2" - 1\ 3/4"$
3.	Extension rods	28 mm $1\ 1/8"$	38 - 48 mm $1\ 1/2" - 1\ 7/8"$
4.	Extension rods	32 mm $1\ 1/4"$	45 - 64 mm $1\ 3/4" - 2\ 1/2"$

If several jaws selected please specify jaws assembled.

SELECTION OF OPTIONS

- | | | | |
|-----|---|-----|---|
| 1. | HEX 1 rock drill (replaces standard component) | 12. | Hydraulic roll-over (360°) boom head
Specify the boom head dead point
- upwards
- 3 o'clock from front |
| 2. | Hydraulic winch (2 tons) | 13. | Bigger rotation motor (400 Nm) for 51 or 64 mm holes |
| 3. | Pulling device for 22 mm (7/8") rods | 14. | PTX exhaust gas purifier |
| 4. | Chain tracks | 15. | Water flushing kit without water pump |
| 5. | Hydraulic drill steel grinder, Dynaset | 16. | Water pump for water flushing kit |
| 6. | Hydraulic drill steel grinder for integral steels, Sanroc ILH | 17. | Extra manuals |
| 7. | Angle indicator MEC Angie | 18. | First service kit for Commando 300, ID 881 536 39 |
| 8. | TIM 2104 Tamrock inclination angle measuring and controlling system | 19. | Special tools for HL 300, field kit ID 881 537 69 |
| 9. | Electric filling pump for refuelling | | |
| 10. | Electric engine heater | | |
| 11. | Spirit level angle indicator | | |