

370E/410E/460E ADTs

37–46 tons



JOHN DEERE



What's the big idea behind our biggest ADTs?

Customer input, that's what. Equipment owners and operators such as you gave us plenty of big ideas for our reimagined E-Series. Their input, plus a clean-sheet redesign, resulted in our biggest ADT — the 460E, plus the 410E and 370E. All three come loaded with features such as John Deere Interim Tier 4 (IT4) diesel engines. Purpose-built transmissions with eight forward and four reverse gears. Heavy-duty John Deere-built axles with wet-disc brakes. Standard adaptive suspension. Full-time six-wheel drive. Numerous automated functions for simplified operation. And ground-level daily and periodic servicing. With the E-Series, you get everything you need to boost productivity and uptime, and reduce your daily operating costs. Big time.



The 460E is our biggest ADT ever. This 46-ton load hog delivers standard-setting productivity and profitability to your fleet. But if you require a little less of a good thing, opt for a 410E or 370E. Equipped with the same features as their larger sibling but with smaller payloads, you can expect similar impressive performance.

With John Deere WorkSight™, JDLink™ monitoring provides real-time machine utilization and health data, plus location information. Fleet Care proactively suggests maintenance to correct problems early before they create costly downtime. And Service ADVISOR™ Remote enables your dealer to read

diagnostic codes, record performance data, and even update software without a trip to the jobsite. It's the most comprehensive easy-to-use suite of technology available for increasing uptime and productivity while lowering operating costs. And it's only available from John Deere.



EPA IT4/EU Stage IIIB technology used in our ADTs is simple, fuel efficient, fully integrated, and fully supported. It employs field-proven cooled exhaust gas recirculation (EGR) for reducing NO_x, and a diesel particulate filter (DPF) and diesel oxidation catalyst (DOC) to reduce particulate matter.

Key specifications	370E	410E	460E
Net peak power	315 kW (422 hp)	330 kW (443 hp)	359 kW (481 hp)
Operating weight empty	30 782 kg (67,862 lb.)	31 853 kg (70,224 lb.)	32 216 kg (71,024 lb.)
Operating weight loaded	64 412 kg (142,003 lb.)	69 119 kg (152,382 lb.)	74 036 kg (163,221 lb.)
Heaped capacity	20.5 m ³ (26.8 cu. yd.)	22.7 m ³ (29.7 cu. yd.)	25.5 m ³ (33.4 cu. yd.)
Rated payload	33 630 kg (74,141 lb.)	37 266 kg (82,157 lb.)	41 820 kg (92,197 lb.)



Supersize your productivity.

Boasting bigger dump bodies and even faster cycle times, E-Series ADTs deliver big-time productivity. All three models employ light-weight heavy-duty fabricated frames and high-alloy-steel dump bodies, ensuring best-in-class power-to-weight ratios. So you'll haul more material at lower cost per ton than comparable-size trucks. Need maximum productivity for a mining, quarry, or aggregate application? Choose our one-of-a-kind 460E. But regardless of which model you choose, you'll benefit from the same combination of exclusive bottom-line and productivity-boosting features and advantages.



Excellent power-to-weight ratios mean more of your fuel dollars are spent moving material, not the machine — decreasing your cost per ton.

Beyond enhancing fuel efficiency, the E-Series' lightweight design also decreases compaction/rolling resistance for longer tire wear.

Solid-plate dump body design empties completely to minimize carry-back for top fuel efficiency and travel speeds. Available dump body heater helps prevent the load from sticking tight in cold-weather climates.

Purpose-built transmission provides eight forward and four reverse gears to speed cycles and ease maneuverability on congested jobsites.

1. Mirror-mounted indicator lights alert the loading operator when the ADT is at capacity to help maximize productivity and avoid overloading.
2. Standard onboard-weighing system displays the payload on the monitor while loading. What's more, real-time load and tonnage data is transmitted by JDLink, so you can monitor productivity from virtually anywhere.
3. Driveline assist speeds dumping and simplifies operation by automatically applying the service brakes, shifting the transmission into neutral, and increasing engine speed to quickly raise the dump body. Optional tailgate helps retain more material for bigger loads and opens as dump body is raised.

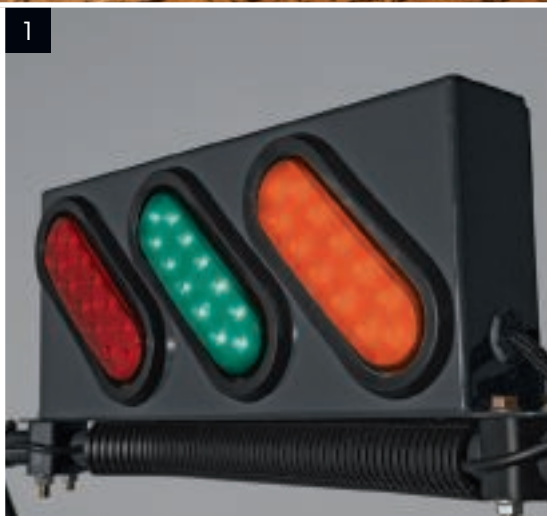

Grounds for an E-Series ADT.

Steep slopes, blinding dust, deep ruts, and slippery muck. If you run ADTs, you know the drill. Loaded with one-of-a-kind productivity-boosting features, our tough, go-anywhere haulers are built to keep materials, and profits, in the fast lane. Regardless of what's underfoot.



1. Heavy-duty four-link rear suspension provides maximum tire contact, for optimum traction, stability, and ability on rough and rutted terrain. Among the many tire options, a wide-profile design provides superior flotation in soft ground conditions.

2. Exclusive adaptive suspension system adjusts to the jobsite, smoothing out the ride and helping keep the cab more stable. Unlike the expensive options available on other trucks, ours is standard equipment.



3. Traction-boosting auto-diff lock engages and disengages as necessary, simplifying operation. Or the operator can engage it on-the-fly.

Downhill-descent control provides consistent, smooth moves on slopes. When the operator's foot comes off the throttle, the system maintains travel speed automatically — reducing service-brake wear while improving productivity.

With our E-Series, you get all-wheel drive, all the time. For easier operation and maximum productivity on all terrain.

Exclusive hill hold helps prevent machine roll-back. When the truck is stopped on a slope, the service brakes remain applied for a short period while the operator's foot moves from the brake to the accelerator. It's an especially valuable advantage in mining applications.

Easy rider.

What operator wouldn't be more productive behind the wheel of an E-Series ADT? Its spacious and quiet climate-controlled cab is loaded with fatigue-beating comfort and convenience features that rival some SUVs. From keyless start and low-effort push-button controls to amenities such as an air-suspension heated high-back seat, tilt/telescoping steering wheel, CD player/radio, and hot/cold-refreshment box. Add to these numerous automated functions and your operators have everything they need to stay comfortably productive and alert, all day long.

Numerous automated features simplify operation and help operators get up to speed quickly. For example, standard over-speed protection automatically controls retarder and transmission gear to ensure that engine speed doesn't exceed preset limits.

Shuttle shifting helps speed cycles, allowing smooth direction changes without coming to a complete stop.

Standard front and rear work lights extend the workday. Exclusive exit lighting stays on for up to five minutes after the engine is shut down, illuminating the way.

1. Two sealed-switch modules provide convenient, fingertip machine control. The main module includes 25 primary machine functions, while the smaller 15-button module operates items such as climate control, lights, and optional heated seat.
2. Intuitive multi-language monitor displays vital operating info, diagnostics, tire pressure, dump-body settings, and payload weight.
3. When activated by the operator, dump-body roll-over protection enables you to preset allowable side-to-side rear chassis unloading angle. If the limit is exceeded, the dump body will not raise and a message appears on the monitor instructing the operator to reposition the truck.
4. Center-mount cab and comprehensive mirror package provide exceptional all-around visibility. A standard rearview camera provides "eyes-in-the-back-of-your-head" visibility, displaying the activity out back on an LCD screen.



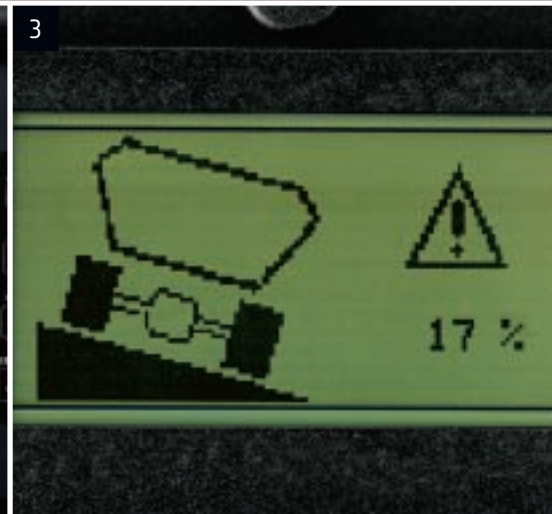



1. Spring-applied, hydraulic-released park brake is extremely durable. Fully hydraulic wet-disc service brakes deliver up to 10,000 hours of life, regardless of the application.

2. Heavy-duty, purpose-built John Deere axles deliver high-hour durability. All three are independently pressure-lubed and filtered, eliminating the risk of cross-contamination. The brake circuits are also cooled.

3. Engine, hydraulic, transmission, and service-brake coolers employ a hydraulic-drive fan that runs only as fast or as often as necessary, helping conserve power and fuel. A reversible option back-blows cooler cores, minimizing manual clean-out.

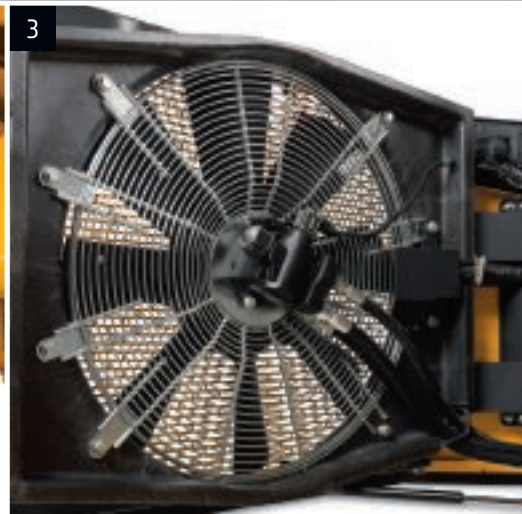



Nothing runs like a Deere, because nothing is built like it.

Designed and manufactured with state-of-the-art tools and techniques by a quality-conscious workforce at our world-class facility in Davenport, Iowa, the E-Series boasts an abundance of uptime-boosting advantages. Their purpose-built powertrains incorporate PowerTech™ 13.5-L IT4 diesels and heavy-duty John Deere-built axles. High-alloy-steel dump bodies and chassis deliver superior strength and rigidity without excess weight. And highly efficient cooling systems with on-demand fans help preserve precious fuel. That's just for starters. To learn more, read on. Then get to your John Deere dealer for all the details. When you know how they're built, you'll run a Deere.

They weigh less than most trucks, but there's nothing light-weight about our trucks. Their fabricated chassis and high-alloy-steel dump bodies provide plenty of long-term strength and rigidity. In fact, they're so tough, they're backed by our three-year/10,000-hour StructurALL™ warranty.

Heavy-duty 13.5-L wet-sleeve John Deere diesels have proven themselves in a wide variety of applications. And they're utilized in numerous other earthmoving and agricultural machines throughout the world, so parts and filters are readily available.

Auto shutdown turns off the engine after an owner-determined period of inactivity. Helps save fuel while reducing emissions, warranty hours, and wear on powertrain and hydraulic systems.

Designed specifically for the E-Series, inboard wet-disc brakes run cool, clean, and unexposed. Combined with the strongest transmission retarder in the industry, they help ensure consistent stops and maximum brake life.

Seamless diesel particulate filter (DPF) cleaning happens automatically without impacting machine productivity. Periodic DPF ash removal is condition-based and should be performed by your John Deere dealer when indicated by the monitor. Actual intervals are affected by machine application and maintenance practices.

Exclusive cool-down feature increases turbocharger reliability by allowing the engine to idle down based on heat load prior to shutting off.

4. Long-term durability demands big-time strength in the critical articulation/oscillation joint. And the E-Series doesn't disappoint. Widely spaced oversize pins and roller bearings, stay-tight oscillation bearing, and the largest throat/tube diameter on any ADT all shout best-in-class.



Wide-open ground-level servicing lets you hit the ground running.

Your maintenance manager and service techs are going to like what they see and read on these pages. And it's the participants in our Customer Advocate service advisory group who get the credit. After all, they're the ones who dug in their heels and insisted on ground-level daily and periodic service access. They talked, we listened, and you're the beneficiary. But that was only part of the story. Keeping an open mind, we added swing-out fans and coolers for quick and easy cleaning. Plus, standard tire-pressure monitoring, common hydraulic and transmission oils, greaseless bushings, and numerous other features that help stretch your dollars and avoid taxing your service personnel.

Open wide and be "awed" — all daily checks and refueling are done from the ground. Even periodic service is simple, with banked vertical hydraulic, transmission, fuel, and engine oil filters. Fluid-sample ports, jump-start terminals, and electrical disconnect switch are also all front and center.

Since end-of-the-shift servicing often takes place after dusk, we added a convenient under-hood light to help show the way.

If something goes wrong, the enhanced monitor provides diagnostic codes and supporting info to assist in pinpointing the problem without a laptop computer.

See-through fluid reservoirs and sight gauges provide noninvasive "at-a-glance" fluid checks.

Greaseless pins and bushings are used throughout, but not in the articulation joint and oscillation area. By customer request, those items employ lube banks that bring difficult-access zerks within easy reach. And a convenient lube and maintenance chart helps ensure that nothing gets overlooked.

Integrated tire-pressure/temperature-monitoring system helps you maximize tire life and fuel efficiency. If pressure drops by 10 percent, a passive alarm appears on the monitor. Further decreases or overheating result in an audible warning, and an email alert is sent to you via JDLink.

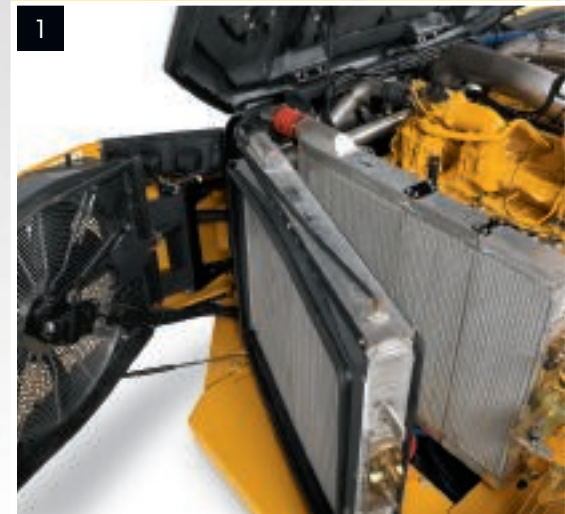

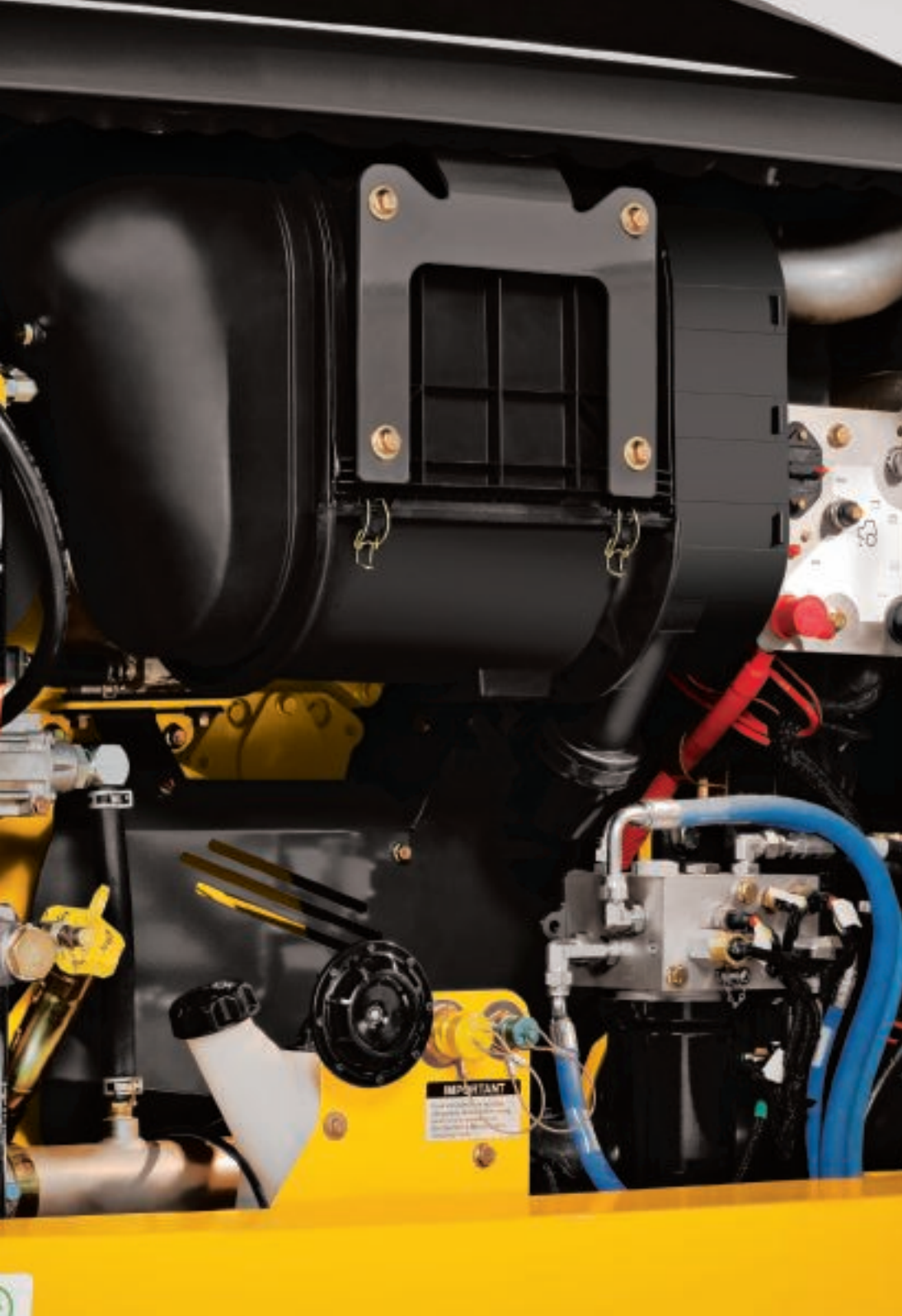

1. Hinged swing-out fans and coolers open wide to reveal the cores, making clean-out quick and easy.
2. Cab can be tilted in minutes without special tools, for convenient component access.
3. Diagnostic test ports and available fluid-sample ports help speed preventive maintenance and troubleshooting.
4. Available quick-service fluid-evacuation points, standard easy-access vertical filters, environmental drains, and common oils help speed periodic maintenance and increase uptime.
5. Our fast-fill option would make a pit crew proud. Takes less than two minutes to refuel, getting you back into the rat race more quickly.

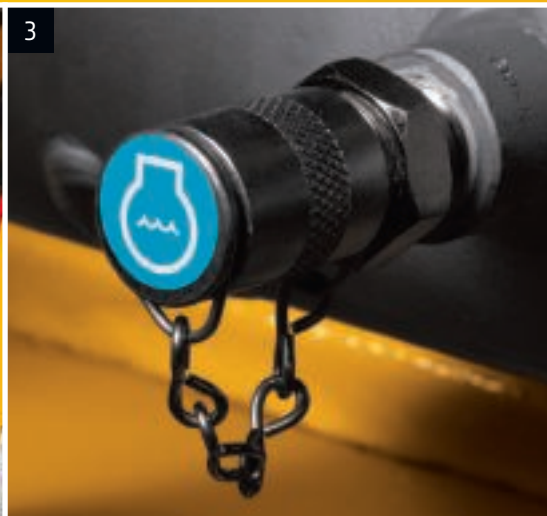
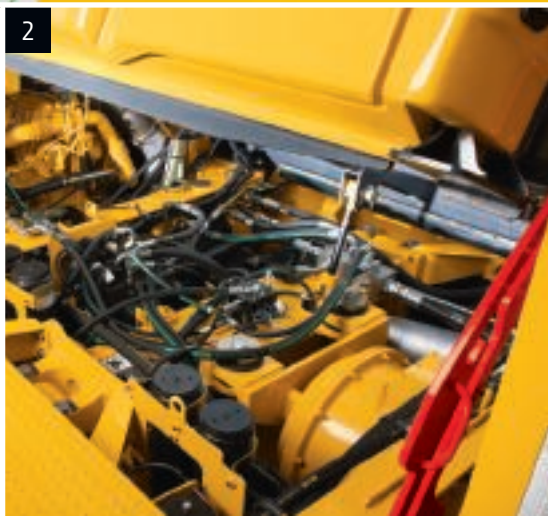
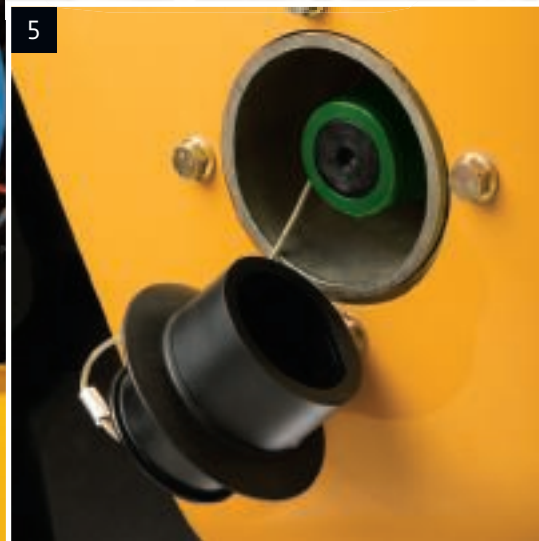

370E



Engine		370E	
Manufacturer and Model	John Deere PowerTech™ 6135		
Non-Road Emission Standards	EPA Interim Tier 4/EU Stage IIIB		
Configuration	6-cylinder inline with variable-geometry turbocharger (VGT) and exhaust gas recirculation (EGR)		
Valves per Cylinder	4		
Displacement	13.5 L (824 cu. in.)		
Net Peak Power (ISO 9249)	315 kW (422 hp) at 1,900 rpm		
Net Peak Torque (ISO 9249)	2100 Nm (1,549 lb.-ft.) at 1,200 rpm		
Aspiration	Twin turbocharged and charge air cooled		
Fuel System	Mechanically actuated electronic unit injection, with 10- and 4-micron filtration and water separator		
Cold-Start Aid	Optional ether start, block heater, and diesel-fired coolant heater		
Cooling			
Engine Cooling	Liquid cooled with single-pass radiators and remote pressurized coolant tank		
Powertrain			
Transmission		8-speed forward, 4-speed reverse countershaft/planetary type with integral retarder and torque-proportioning differential	
Torque Converter	3-element, 1-way stator clutch; multi-disc lockup		
Retarder	Integral, gear dependent, hydrodynamic, oil-to-air cooled, variable, fully automatic		
Output Differential	Torque-proportioning, planetary-type, Interaxle Differential Lock (IDL) with PowerShift™ lockup clutch		
Shift Controls	Fully automatic, electronically modulated PowerShift, load-speed adaptive with gear-skip and gear-hunting protection		
Operator Interface	Push-button FNR, selectable speed- and gear-range limits, selectable retarder aggressiveness, downhill-descent control, and gear-hold		
Speeds	<i>Forward</i>	<i>Reverse</i>	
Gear 1	5 km/h (3 mph)	5 km/h (3 mph)	
Gear 2	7 km/h (4 mph)	8 km/h (5 mph)	
Gear 3	11 km/h (7 mph)	11 km/h (7 mph)	
Gear 4	16 km/h (10 mph)	16 km/h (10 mph)	
Gear 5	23 km/h (14 mph)	—	
Gear 6	32 km/h (20 mph)	—	
Gear 7	46 km/h (29 mph)	—	
Gear 8	53 km/h (33 mph)	—	
Axles			
Differential	Helical transfer gears, spiral bevel, hydraulically actuated PowerShift Cross-axle Differential Lock (CDL)		
Final Drive	Extreme-duty outboard-mounted planetary; cooled and filtered oil		
Brake System			
Service	Dual-circuit, hydraulically actuated, wet multi-disc, force cooled, inboard mounted		
Parking	Spring-applied hydraulically released, driveline-mounted, dry-disc, self-adjusting for pad wear		
Auxiliary	Fully automatic; transmission mounted, gear dependent; hydrodynamic retarder with selectable levels		
Hydraulics			
Type	Closed-center, variable-displacement, load-sensing system		
Main Pump	Variable displacement, axial piston		
Secondary Steering Pump	Ground-driven gear pump with hydraulic unloader valve		
Dump Cylinders	Dual-acting, single-stage with heat-treated, chrome-plated, and polished cylinder rods; hardened steel replaceable bushings and pivot pins		
Cycle Time			
Power Down	7 sec.		
Raise Time	13 sec.		
Electrical			
Voltage	24 volt		
Number of Batteries	2 – 12 volt		
Battery Capacity	950 CCA standard (2) / 1,400 CCA optional (2)		
Alternator	28 volt / 100 amp		
Steering System			
Type	2 hydraulically actuated, double-acting hydraulic cylinders; ground-driven secondary steering pump		
Angle	45 deg. side to side		
Lock-to-Lock Turns	4.2		
Suspension			
Front	Semi-independent leading A-frame geometry with transverse link for lateral restraint and self-leveling oil-filled struts with remote nitrogen-charged accumulators		
Rear	Load-equalizing, pivoting walking beams with laminated suspension blocks, tri-link geometry, and transverse links for lateral restraint		
Dump Body			
Type	High-strength steel		
Capacity			
Struck	16.3 m ³ (21.3 cu. yd.)		
Heaped at 2:1 ISO 6483 Ratio	20.5 m ³ (26.8 cu. yd.)		
With Optional Tailgate	21.4 m ³ (28.0 cu. yd.)		



Dump Body (continued)	370E
Maximum Dump Angle	70 deg.
Heater	Body ducted to accept optional exhaust heating

Serviceability

Ground-Level Service	
Fluids and Filters	Ground-level engine, transmission, and axle oil-level check and filter replacement; ground-level fueling and fuel filter replacement
Coolers	Swing-out coolers for easy cleaning; optional reverse-directional fans for cleaning
Fluid Sampling	Standard fluid-sampling ports; optional quick-service ports

Refill Capacities	
Fuel Tank	609 L (161.0 gal.)
Engine Oil with Filter	43 L (11.4 gal.)
Engine Coolant	93 L (24.6 gal.)
Transmission Fluid (refill)	60 L (15.9 gal.)
Hydraulic Reservoir	242 L (64.0 gal.)
Axle Fluid with Filter	
Front	62 L (16.4 gal.)
Mid	62 L (16.4 gal.)
Rear	68 L (18.0 gal.)

Operating Weights

With Standard Equipment	<i>Empty</i>	<i>Loaded</i>
Front	16 630 kg (36,663 lb.)	20 787 kg (45,828 lb.)
Middle	7152 kg (15,767 lb.)	21 888 kg (48,255 lb.)
Rear	7000 kg (15,432 lb.)	21 736 kg (47,920 lb.)
Total	30 782 kg (67,862 lb.)	64 412 kg (142,003 lb.)
Rated Payload	33 630 kg (74,141 lb.)	

Optional Components (add to standard weights)

Tailgate	840 kg (1,852 lb.)
Body Liners	1256 kg (2,769 lb.)
Tires	
29.5R25	1032 kg (2,275 lb.)
875/65R29	1964 kg (4,330 lb.)

Operating Dimensions

Turning Circle Radius	
Inside	4.62 m (15 ft. 2 in.)
Outside	8.92 m (29 ft. 3 in.)

Machine Dimensions

A Width with Mirrors in Operating Position	3.80 m (12 ft. 5 in.)
B Length	10.81 m (35 ft. 6 in.)
C Height	3.81 m (12 ft. 6 in.)
Overall Height (suspension lowered 75 mm [3 in.])	3.73 m (12 ft. 3 in.)
Tires	
Wheel	26.5R25 29.5R25 875/65R29
Wheel	25x22.00/3.0 3-piece 25x25.00/3.5 5-piece 29x27.00/3.5 5-piece
D Tire-Track Width	2.77 m (9 ft. 1 in.)
E Width Over Tires	3.44 m (11 ft. 3 in.)
F Width Over Fenders	3.44 m (11 ft. 3 in.)
G Ground Clearance	0.53 m (21 in.)
H Dump Body Height, Dump Position	6.88 m (22 ft. 7 in.)
I Dump Body Side Rail Height	3.26 m (10 ft. 8 in.)
J Dump Body Dump Lip Height, Transport Position	3.61 m (11 ft. 10 in.)
K Dump Body Ground Clearance, Dump Position	0.791 m (31 in.)
L Dump Body Length	5.97 m (19 ft. 7 in.)
M Rear Axle Centerline to Rear of Dump Body	1.48 m (4 ft. 10 in.)
N Mid Axle to Rear Axle Centerline	1.96 m (6 ft. 5 in.)
O Front Axle to Mid Axle Centerline	4.63 m (15 ft. 2 in.)
P Front Axle Centerline to Front of Machine	2.74 m (9 ft. 0 in.)
Q Approach Angle	24 deg.
R Maximum Dump Angle	70 deg.

Shipping Dimensions

Overall Width	
Dump Body	3.13 m (10 ft. 3 in.)
Tailgate Installed	3.44 m (11 ft. 3 in.)

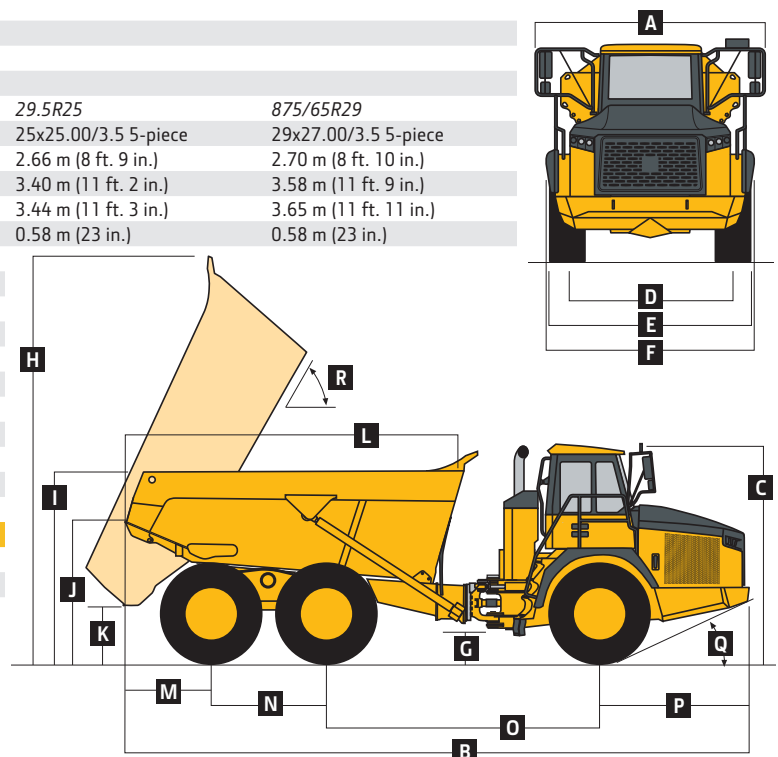

410E



Engine	410E	
Manufacturer and Model	John Deere PowerTech™ 6135	
Non-Road Emission Standards	EPA Interim Tier 4/EU Stage IIIB	
Configuration	6-cylinder inline with variable-geometry turbocharger (VGT) and exhaust gas recirculation (EGR)	
Valves per Cylinder	4	
Displacement	13.5 L (824 cu. in.)	
Net Peak Power (ISO 9249)	330 kW (443 hp) at 1,900 rpm	
Net Peak Torque (ISO 9249)	2284 Nm (1,685 lb.-ft.) at 1,200 rpm	
Aspiration	Twin turbocharged and charge air cooled	
Fuel System	Mechanically actuated electronic unit injection, with 10- and 4-micron filtration and water separator	
Cold-Start Aid	Optional ether start, block heater, and diesel-fired coolant heater	
Cooling		
Engine Cooling	Liquid cooled with single-pass radiators and remote pressurized coolant tank	
Powertrain		
Transmission	8-speed forward, 4-speed reverse countershaft/planetary type with integral retarder and torque-proportioning differential	
Torque Converter	3-element, 1-way stator clutch; multi-disc lockup	
Retarder	Integral, gear dependent, hydrodynamic, oil-to-air cooled, variable, fully automatic	
Output Differential	Torque-proportioning, planetary-type, Interaxle Differential Lock (IDL) with PowerShift™ lockup clutch	
Shift Controls	Fully automatic, electronically modulated PowerShift, load-speed adaptive with gear-skip and gear-hunting protection	
Operator Interface	Push-button FNR, selectable speed- and gear-range limits, selectable retarder aggressiveness, downhill-descent control, and gear-hold	
Speeds	<i>Forward</i>	<i>Reverse</i>
Gear 1	5 km/h (3 mph)	6 km/h (4 mph)
Gear 2	8 km/h (5 mph)	8 km/h (5 mph)
Gear 3	12 km/h (7 mph)	12 km/h (7 mph)
Gear 4	17 km/h (11 mph)	17 km/h (11 mph)
Gear 5	24 km/h (15 mph)	—
Gear 6	34 km/h (21 mph)	—
Gear 7	48 km/h (30 mph)	—
Gear 8	55 km/h (34 mph)	—
Axles		
Differential	Helical transfer gears, spiral bevel, hydraulically actuated PowerShift Cross-axle Differential Lock (CDL)	
Final Drive	Extreme-duty outboard-mounted planetary; cooled and filtered oil	
Brake System		
Service	Dual-circuit, hydraulically actuated, wet multi-disc, force cooled, inboard mounted	
Parking	Spring-applied hydraulically released, driveline-mounted, dry-disc, self-adjusting for pad wear	
Auxiliary	Fully automatic; transmission mounted, gear dependent; hydrodynamic retarder with selectable levels	
Hydraulics		
Type	Closed-center, variable-displacement, load-sensing system	
Main Pump	Variable displacement, axial piston	
Secondary Steering Pump	Ground-driven gear pump with hydraulic unloader valve	
Dump Cylinders	Dual-acting, single-stage with heat-treated, chrome-plated, and polished cylinder rods; hardened steel replaceable bushings and pivot pins	
Cycle Time		
Power Down	7 sec.	
Raise Time	13 sec.	
Electrical		
Voltage	24 volt	
Number of Batteries	2 – 12 volt	
Battery Capacity	950 CCA standard (2) / 1,400 CCA optional (2)	
Alternator	28 volt / 100 amp	
Steering System		
Type	2 hydraulically actuated, double-acting hydraulic cylinders; ground-driven secondary steering pump	
Angle	45 deg. side to side	
Lock-to-Lock Turns	4.2	
Suspension		
Front	Semi-independent leading A-frame geometry with transverse link for lateral restraint and self-leveling oil-filled struts with remote nitrogen-charged accumulators	
Rear	Load-equalizing, pivoting walking beams with laminated suspension blocks, tri-link geometry, and transverse links for lateral restraint	
Dump Body		
Type	High-strength steel	
Capacity		
Struck	17.8 m ³ (23.3 cu. yd.)	
Heaped at 2:1 ISO 6483 Ratio	22.7 m ³ (29.7 cu. yd.)	
With Optional Tailgate	23.7 m ³ (30.9 cu. yd.)	



Dump Body (continued)	410E
Maximum Dump Angle	70 deg.
Heater	Body ducted to accept optional exhaust heating

Serviceability

Ground-Level Service	
Fluids and Filters	Ground-level engine, transmission, and axle oil-level check and filter replacement; ground-level fueling and fuel filter replacement
Coolers	Swing-out coolers for easy cleaning; optional reverse-directional fans for cleaning
Fluid Sampling	Standard fluid-sampling ports; optional quick-service ports

Refill Capacities	
Fuel Tank	609 L (161.0 gal.)
Engine Oil with Filter	43 L (11.4 gal.)
Engine Coolant	93 L (24.6 gal.)
Transmission Fluid (refill)	60 L (15.9 gal.)
Hydraulic Reservoir	242 L (64.0 gal.)
Axle Fluid with Filter	
Front	62 L (16.4 gal.)
Mid	62 L (16.4 gal.)
Rear	68 L (18.0 gal.)

Operating Weights

With Standard Equipment	<i>Empty</i>	<i>Loaded</i>
Front	16 747 kg (36,921 lb.)	21 487 kg (47,371 lb.)
Middle	7629 kg (16,819 lb.)	23 892 kg (52,673 lb.)
Rear	7477 kg (16,484 lb.)	23 740 kg (52,338 lb.)
Total	31 853 kg (70,224 lb.)	69 119 kg (152,382 lb.)
Rated Payload	37 266 kg (82,157 lb.)	

Optional Components (add to standard weights)

Tailgate	847 kg (1,867 lb.)
Body Liners	1348 kg (2,972 lb.)
875/65R29 Tires	1964 kg (4,330 lb.)

Operating Dimensions

Turning Circle Radius	
Inside	4.63 m (15 ft. 2 in.)
Outside	8.90 m (29 ft. 2 in.)

Machine Dimensions

A Width with Mirrors in Operating Position	3.80 m (12 ft. 5 in.)
B Length	10.81 m (35 ft. 6 in.)
C Height	3.86 m (12 ft. 8 in.)
Overall Height (suspension lowered 75 mm [3 in.])	3.78 m (12 ft. 5 in.)
Tires	
Wheel	29.5R25 875/65R29
	25x25.00/3.5 5-piece 29x27.00/3.5 5-piece
D Tire-Track Width	2.66 m (8 ft. 9 in.) 2.70 m (8 ft. 10 in.)
E Width Over Tires	3.41 m (11 ft. 2 in.) 3.58 m (11 ft. 9 in.)
F Width Over Fenders	3.44 m (11 ft. 3 in.) 3.65 m (11 ft. 11 in.)
G Ground Clearance	0.58 m (23 in.) 0.58 m (23 in.)
H Dump Body Height, Dump Position	6.92 m (22 ft. 8 in.)
I Dump Body Side Rail Height	3.30 m (10 ft. 10 in.)
J Dump Body Dump Lip Height, Transport Position	3.62 m (11 ft. 11 in.)
K Dump Body Ground Clearance, Dump Position	0.843 m (33 in.)
L Dump Body Length	5.97 m (19 ft. 7 in.)
M Rear Axle Centerline to Rear of Dump Body	1.48 m (4 ft. 10 in.)
N Mid Axle to Rear Axle Centerline	1.96 m (6 ft. 5 in.)
O Front Axle to Mid Axle Centerline	4.63 m (15 ft. 2 in.)
P Front Axle Centerline to Front of Machine	2.74 m (9 ft. 0 in.)
Q Approach Angle	26 deg.
R Maximum Dump Angle	70 deg.

Shipping Dimensions

Overall Width	
Dump Body	3.33 m (10 ft. 11 in.)
Tailgate Installed	3.62 m (11 ft. 10 in.)

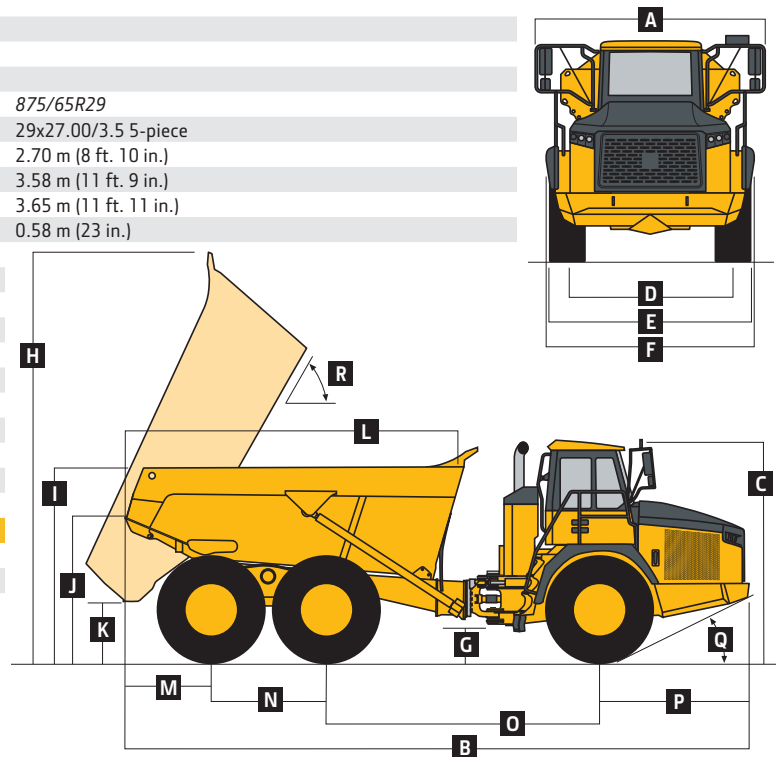

460E



Engine	460E	
Manufacturer and Model	John Deere PowerTech™ 6135	
Non-Road Emission Standards	EPA Interim Tier 4/EU Stage IIIB	
Configuration	6-cylinder inline with variable-geometry turbocharger (VGT) and exhaust gas recirculation (EGR)	
Valves per Cylinder	4	
Displacement	13.5 L (824 cu. in.)	
Net Peak Power (ISO 9249)	359 kW (481 hp) at 1,900 rpm	
Net Peak Torque (ISO 9249)	2401 Nm (1,771 lb.-ft.) at 1,400 rpm	
Aspiration	Twin turbocharged and charge air cooled	
Fuel System	Mechanically actuated electronic unit injection, with 10- and 4-micron filtration and water separator	
Cold-Start Aid	Optional ether start, block heater, and diesel-fired coolant heater	
Cooling		
Engine Cooling	Liquid cooled with single-pass radiators and remote pressurized coolant tank	
Powertrain		
Transmission	8-speed forward, 4-speed reverse countershaft/planetary type with integral retarder and torque-proportioning differential	
Torque Converter	3-element, 1-way stator clutch; multi-disc lockup	
Retarder	Integral, gear dependent, hydrodynamic, oil-to-air cooled, variable, fully automatic	
Output Differential	Torque-proportioning, planetary-type, Interaxle Differential Lock (IDL) with PowerShift™ lockup clutch	
Shift Controls	Fully automatic, electronically modulated PowerShift, load-speed adaptive with gear-skip and gear-hunting protection	
Operator Interface	Push-button FNR, selectable speed- and gear-range limits, selectable retarder aggressiveness, downhill-descent control, and gear-hold	
Speeds	<i>Forward</i>	<i>Reverse</i>
Gear 1	5 km/h (3 mph)	6 km/h (4 mph)
Gear 2	8 km/h (5 mph)	8 km/h (5 mph)
Gear 3	12 km/h (7 mph)	12 km/h (7 mph)
Gear 4	17 km/h (11 mph)	17 km/h (11 mph)
Gear 5	24 km/h (15 mph)	—
Gear 6	34 km/h (21 mph)	—
Gear 7	48 km/h (30 mph)	—
Gear 8	55 km/h (34 mph)	—
Axles		
Differential	Helical transfer gears, spiral bevel, hydraulically actuated PowerShift Cross-axle Differential Lock (CDL)	
Final Drive	Extreme-duty outboard-mounted planetary; cooled and filtered oil	
Brake System		
Service	Dual-circuit, hydraulically actuated, wet multi-disc, force cooled, inboard mounted	
Parking	Spring-applied hydraulically released, driveline-mounted, dry-disc, self-adjusting for pad wear	
Auxiliary	Fully automatic; transmission mounted, gear dependent; hydrodynamic retarder with selectable levels	
Hydraulics		
Type	Closed-center, variable-displacement, load-sensing system	
Main Pump	Variable displacement, axial piston	
Secondary Steering Pump	Ground-driven gear pump with hydraulic unloader valve	
Dump Cylinders	Dual-acting, single-stage with heat-treated, chrome-plated, and polished cylinder rods; hardened steel replaceable bushings and pivot pins	
Cycle Time		
Power Down	7 sec.	
Raise Time	13 sec.	
Electrical		
Voltage	24 volt	
Number of Batteries	2 – 12 volt	
Battery Capacity	950 CCA standard (2) / 1,400 CCA optional (2)	
Alternator	28 volt / 100 amp	
Steering System		
Type	2 hydraulically actuated, double-acting hydraulic cylinders; ground-driven secondary steering pump	
Angle	45 deg. side to side	
Lock-to-Lock Turns	4.2	
Suspension		
Front	Semi-independent leading A-frame geometry with transverse link for lateral restraint and self-leveling oil-filled struts with remote nitrogen-charged accumulators	
Rear	Load-equalizing, pivoting walking beams with laminated suspension blocks, tri-link geometry, and transverse links for lateral restraint	
Dump Body		
Type	High-strength steel	
Capacity		
Struck	20.6 m ³ (26.9 cu. yd.)	
Heaped at 2:1 ISO 6483 Ratio	25.5 m ³ (33.4 cu. yd.)	
With Optional Tailgate	26.9 m ³ (35.1 cu. yd.)	



Dump Body (continued)	460E
Maximum Dump Angle	70 deg.
Heater	Body ducted to accept optional exhaust heating

Serviceability

Ground-Level Service	
Fluids and Filters	Ground-level engine, transmission, and axle oil-level check and filter replacement; ground-level fueling and fuel filter replacement
Coolers	Swing-out coolers for easy cleaning; optional reverse-directional fans for cleaning
Fluid Sampling	Standard fluid-sampling ports; optional quick-service ports

Refill Capacities	
Fuel Tank	609 L (161.0 gal.)
Engine Oil with Filter	43 L (11.4 gal.)
Engine Coolant	93 L (24.6 gal.)
Transmission Fluid (refill)	60 L (15.9 gal.)
Hydraulic Reservoir	242 L (64.0 gal.)
Axle Fluid with Filter	
Front	62 L (16.4 gal.)
Mid	62 L (16.4 gal.)
Rear	68 L (18.0 gal.)

Operating Weights

With Standard Equipment	<i>Empty</i>	<i>Loaded</i>
Front	16 976 kg (37,421 lb.)	22 517 kg (49,641 lb.)
Middle	7697 kg (16,969 lb.)	25 836 kg (56,958 lb.)
Rear	7545 kg (16,634 lb.)	25 684 kg (56,623 lb.)
Total	32 216 kg (71,024 lb.)	74 036 kg (163,221 lb.)
Rated Payload	41 820 kg (92,197 lb.)	

Optional Components (add to standard weights)

Tailgate	919 kg (2,026 lb.)
Body Liners	1365 kg (3,009 lb.)
875/65R29 Tires	1964 kg (4,330 lb.)

Operating Dimensions

Turning Circle Radius	
Inside	4.63 m (15 ft. 2 in.)
Outside	8.90 m (29 ft. 2 in.)

Machine Dimensions

A Width with Mirrors in Operating Position	3.80 m (12 ft. 5 in.)	
B Length	10.81 m (35 ft. 6 in.)	
C Height	3.86 m (12 ft. 8 in.)	
Overall Height (suspension lowered 75 mm [3 in.])	3.78 m (12 ft. 5 in.)	
Tires		
Wheel	29.5R25	875/65R29
D Tire-Track Width	2.66 m (8 ft. 9 in.)	2.70 m (8 ft. 10 in.)
E Width Over Tires	3.41 m (11 ft. 2 in.)	3.58 m (11 ft. 9 in.)
F Width Over Fenders	3.44 m (11 ft. 3 in.)	3.65 m (11 ft. 11 in.)
G Ground Clearance	0.58 m (23 in.)	0.58 m (23 in.)
H Dump Body Height, Dump Position	7.00 m (22 ft. 11 in.)	
I Dump Body Side Rail Height	3.47 m (11 ft. 5 in.)	
J Dump Body Dump Lip Height, Transport Position	3.78 m (12 ft. 5 in.)	
K Dump Body Ground Clearance, Dump Position	0.843 m (33 in.)	
L Dump Body Length	6.01 m (19 ft. 8 in.)	
M Rear Axle Centerline to Rear of Dump Body	1.48 m (4 ft. 10 in.)	
N Mid Axle to Rear Axle Centerline	1.96 m (6 ft. 5 in.)	
O Front Axle to Mid Axle Centerline	4.63 m (15 ft. 2 in.)	
P Front Axle Centerline to Front of Machine	2.74 m (9 ft. 0 in.)	
Q Approach Angle	26 deg.	
R Maximum Dump Angle	70 deg.	

Shipping Dimensions

Overall Width	
Dump Body	3.36 m (11 ft. 0 in.)
Tailgate Installed	3.64 m (11 ft. 11 in.)

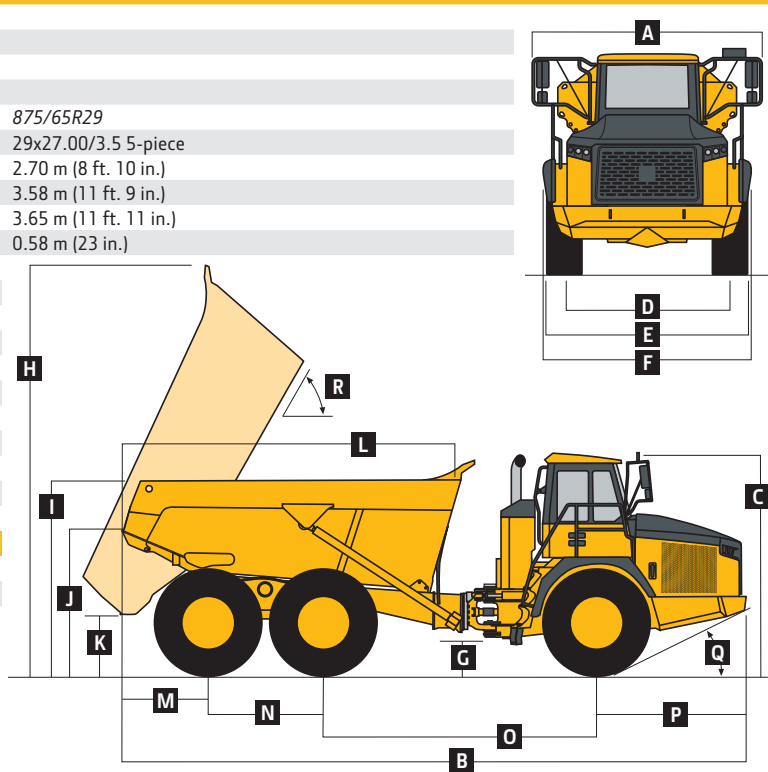

Additional equipment

Key: ● Standard ▲ Optional or special

See your John Deere dealer for further information.

370E	410E	460E	Engine
●	●	●	Meets EPA Interim Tier 4/EU Stage IIIB emissions
●	●	●	John Deere PowerTech™ 6135 — 13.5L (824 cu. in.) inline 6
●	●	●	Wet-sleeve cylinder liners
●	●	●	Variable-geometry turbocharger (VGT)
●	●	●	External cooled exhaust gas recirculation (EGR)
●	●	●	Dual-element air cleaner
●	●	●	Precleaner
●	●	●	Fuel/water separator
●	●	●	Ground-level fueling
▲	▲	▲	Fast fill
●	●	●	Serpentine drive belt with automatic tensioner
▲	▲	▲	Ether start aid (recommended below -1 deg. C [30 deg. F])
▲	▲	▲	Block heater (recommended below -18 deg. C [0 deg. F])
▲	▲	▲	Diesel-fired coolant heater (DFCH) (required below -25 deg. C [-13 deg. F])
●	●	●	Programmable auto-shutdown
●	●	●	Automatic turbo cool-down/shut-down timer
●	●	●	Flat-black exhaust stack
▲	▲	▲	Chrome exhaust stack
▲	▲	▲	Severe-duty fuel filter
▲	▲	▲	Severe-duty fuel filter with heater
Cooling			
●	●	●	Dual hydraulically driven, side-mounted fans
●	●	●	Side-mounted radiators (2), charge-air cooler, front and mid-axle coolers, transmission cooler, hydraulic cooler, air-conditioner condenser, and fuel cooler
●	●	●	Integral engine oil cooler
●	●	●	Remote pressurized coolant reservoir
●	●	●	John Deere COOL-GARD™ II long-life engine coolant
▲	▲	▲	Reversing fans
Powertrain			
●	●	●	Transmission diagnostic ports
●	●	●	Transmission oil-temperature self-protection
●	●	●	Remote-mounted spin-on transmission oil filters
●	●	●	Remote-mounted replaceable-element axle-oil filters
●	●	●	Axle-oil temperature and lube-pressure sensing
●	●	●	Axle radial-shaft-seal grease barrier with lubrication fitting
●	●	●	Selectable Auto Differential Lock (ADL)
●	●	●	Automatic engaging retarder with selectable aggressiveness

370E	410E	460E	Electrical System
●	●	●	24-volt system voltage
●	●	●	100-amp alternator
●	●	●	Solid-state electrical distribution system
●	●	●	Battery disconnect
●	●	●	Batteries, 2 x 950 CCA
▲	▲	▲	Batteries, 2 x 1,400 CCA
●	●	●	Drive lights
●	●	●	Stair and service lights
▲	▲	▲	Deluxe work lights, front and rear
●	●	●	LED rear turn signals/brake lights
●	●	●	Electric horn
●	●	●	Reverse alarm
▲	▲	▲	Beacon/strobe light
▲	▲	▲	24-volt to 12-volt 15-amp converter
▲	▲	▲	24-volt to 12-volt 25-amp converter
Hydraulic System			
●	●	●	Closed-center, load-sensing system
●	●	●	Axial-piston, variable-displacement main pump
●	●	●	Single-stage, dual-acting, dump-body tip cylinders
●	●	●	Electrohydraulic dump-body control
Steering System			
●	●	●	Ground-driven secondary steering pump
Operator Station			
●	●	●	ROPS/FOPS certification
●	●	●	Keyless start
●	●	●	Tilt cab
●	●	●	Programmable dump-body control settings
●	●	●	Air conditioner
●	●	●	Heater
●	●	●	AM/FM radio/CD player
●	●	●	Rear window guard
●	●	●	Wiper/washer with intermittent control
●	●	●	Tilt and telescoping steering wheel
●	●	●	Fully adjustable, air-suspension, heated, high-back cloth and leather seat
▲	▲	▲	Air-suspension, low-back, cloth seat
●	●	●	76-mm (3 in.) retractable operator seat belt
●	●	●	Foldaway trainer seat with retractable seat belt
●	●	●	12-volt power outlet
●	●	●	Cup holder
●	●	●	Cooled/heated lunch box
●	●	●	Reverse camera
●	●	●	Ashtray and 12-volt cigarette lighter

370E	410E	460E	Operator Station (continued)
▲	▲	▲	Electric adjustable and heated mirrors
●	●	●	Deluxe monitor: Speedometer / Fuel gauge / Transmission oil temperature gauge / Engine coolant temperature gauge / Gear indicator / Tachometer / Battery voltage / Hour meter / Odometer / Fuel consumption / Trip counter / Trip timer / Trip distance / Metric/Imperial units / Service codes/diagnostics / LED indicator lights and audible alarm / Programmable dump-body rollover protection / Onboard weighing display / Multi-language capability / Tire-pressure-monitoring system warning
●	●	●	2 backlit sealed-switch module functions: Keyless start/stop / Park brake / Transmission controls drive, neutral, and reverse / Transmission gear hold and gear limit / Wiper control / Park lights and headlights / Work lights / Hazard lights / Beacon / Heated mirrors / Retarding aggressiveness / Operator-adjustable speed-limit controls / Traction controls for inter-axle and axles / Dump body up/down / Automatic dump-body control settings / Air-conditioner/heater controls
▲	▲	▲	Dump-body lever control
Dump Body			
●	●	●	Dump-body safety lock bar
▲	▲	▲	Dump-body liner (steel)
▲	▲	▲	Tailgate
▲	▲	▲	Dump-body heater
▲	▲	▲	Less dump body and cylinders
Other			
●			26.5R25 radial earthmovers
▲	●	●	29.5R25 radial earthmovers
▲	▲	▲	875/65R29 radial earthmovers
●	●	●	Remote grease banks
▲	▲	▲	Quick-service bank
●	●	●	Articulation lock
●	●	●	Onboard weighing system with external load lights
●	●	●	Tire-pressure-monitoring system with temperature compensation
●	●	●	Fire extinguisher
●	●	●	JDLink™ Ultimate wireless communication system with 3-year subscription (available in specific countries; see your dealer for details)
▲	▲	▲	JDLink Ultimate dual-mode cellular/satellite wireless communication system with 3-year subscription (available in specific countries; see your dealer for details)

Net engine power is with standard equipment including air cleaner, exhaust system, alternator, and cooling fan at test conditions specified per ISO 9249. Specifications and design subject to change without notice. Wherever applicable, specifications are in accordance with ISO standards. Except where otherwise noted, these specifications are based on units with standard equipment, ROPS cabs, full fuel tanks, and 79-kg (175 lb.) operators; a 370E unit with 26.5R25 radial earthmover tires; and 410E and 460E units with 29.5R25 radial earthmover tires. Capacity and loaded weights are based on 1640-kg/m³ (2,759 lb./cu. yd.) material.

