

# Boomer 282 face drilling rig

Two-boom hydraulic controlled face drilling rig for medium sized underground drifts, with maximum coverage area 45 m<sup>2</sup>



# The “All Star” two-boom rig

Boomer 282 is a world popular face drilling rig installed with two robust BUT booms and available with a variety of rock drills. Stable and highly efficient performance makes it your first choice for medium size drifts mining and tunneling applications.

## + Main benefits

**Designed for** medium size drifts with maximum coverage area up to 45 m<sup>2</sup>.

**Time-proven robust design** and common sense control system ensure great reliability and make it the world's most popular two-boom face drill rig.

**Operator and service friendly.** Open design of the rig body brings easy operation and convenient maintenance.

**Various options** are available for all kinds of operation requests.



World's most popular two-boom face drilling rig with fast, safe and stable drilling performance.



With a variety of options, Boomer 282 is versatile for various kinds of drilling applications.



The robust and reliable components provide an ideal combination of low cost and high productivity.

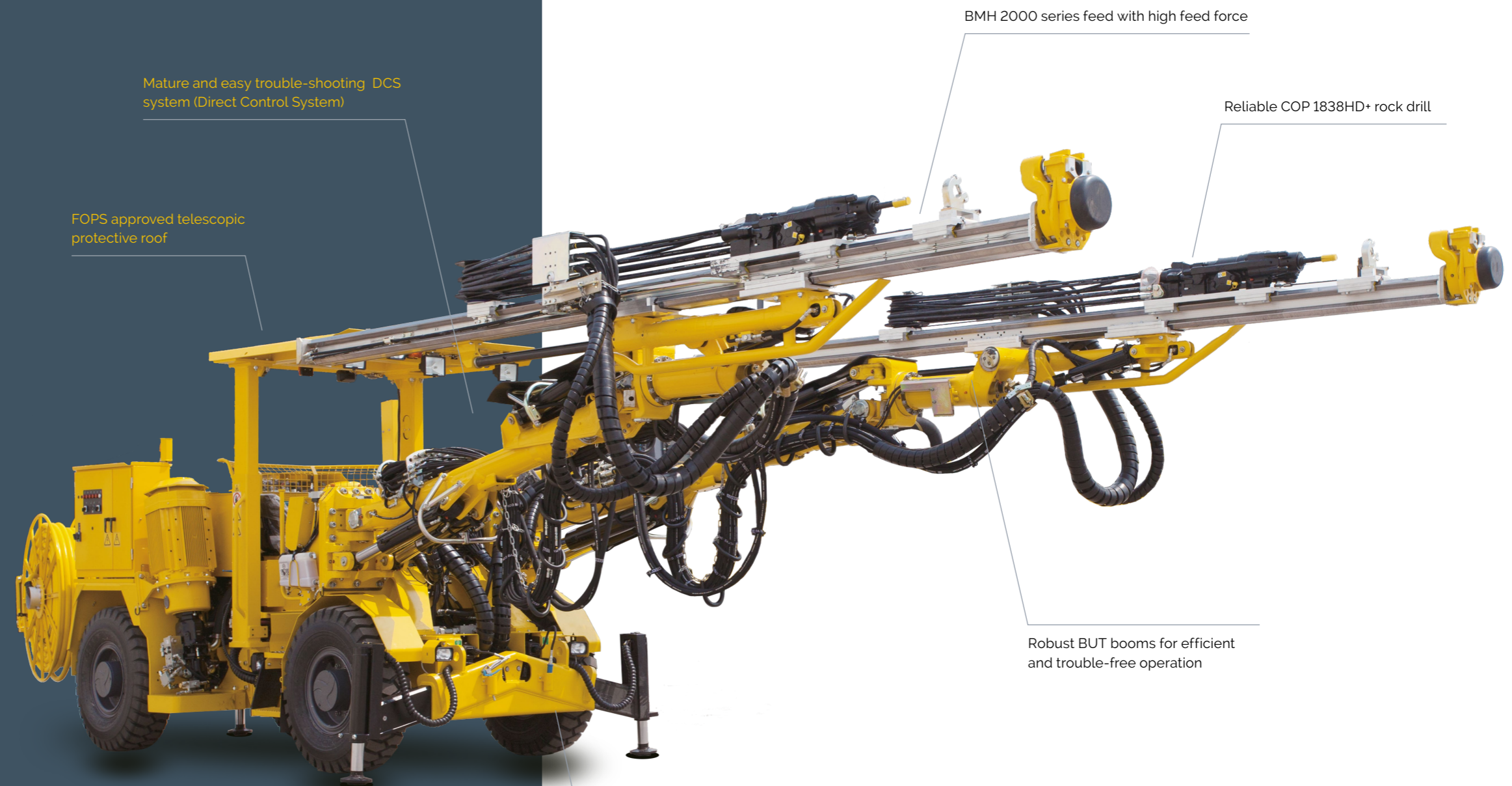

Mature and easy trouble-shooting DCS system (Direct Control System)

FOPS approved telescopic protective roof

BMH 2000 series feed with high feed force

Reliable COP 1838HD+ rock drill

Robust BUT booms for efficient and trouble-free operation

Stable carrier with more engine options to meet your different application requirements

# Excellent performance

With high knowledge and experiences base



## + COP 1800 HD+ series rock drill

The Boomer 282 is equipped with COP 1800 HD+ series rock drill, featured by high efficiency, high penetration rate and excellent drill steel economy with dual-dampening system. With its adjustable stroke settings on rock drill and "Heavy Duty" (HD) front head, it can handle various ground conditions and even the toughest of conditions and operations. The "+" series have recommended service intervals increased by 50%, giving higher machine utilization and reduced running costs.



## + BMH 2000 series feed

The Boomer 282 is installed with strong aluminum beam with extremely high resistance against bending and stress, feed force reaching up to 15 kN. Optional telescopic feed BMHT series for cross section drilling is also available to select.

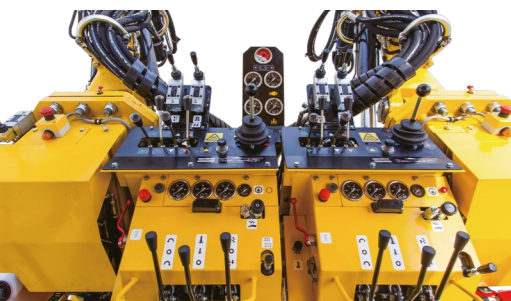

## + Operator station

Excellent visibility, logical control layout, and optional operator cabin ensure improved productivity and safe operation.



## A comprehensive service offering

Even the best equipment needs to be serviced regularly to make sure it sustains peak performance. An Epiroc service solution offers peace of mind, maximizing availability and performance throughout the lifetime of your equipment. We focus on safety, productivity and reliability.

By combining genuine parts and an Epiroc service from our certified technicians, we safeguard your productivity – wherever you are.

## Technical specifications

### Rock drill

	COP 1638HD+	COP 1838HD+
Shank adapter	R38/T38	R38/T38
Height over drill centre	88 mm	88 mm
Length without shank	1 008 mm	1 008 mm
Impact power	16 kW	18 kW
Impact rate	60 Hz	60 Hz
Hydraulic pressure	200 bar	230 bar
Rotation system	Separate rotation	Separate rotation
Rotation speed	0-340/0-215 rpm	0-340/0-215 rpm
Rotation torque, max	640/1 000 Nm	640/1 000 Nm
Lub. air consump. at 2 bar	5 L/s	5 L/s
Weight	175 kg	175 kg
Sound level	<106 dB(A)	<106 dB(A)

### Feed

BMH 2800	BMH 2831	BMH 2837	BMH 2843	BMH 2849
Total length	4 594 mm	5 332 mm	5 942 mm	6 552 mm
Drill rod length	3 090 mm	3 700 mm	4 310 mm	4 920 mm
Hole depth	2 775 mm	3 266 mm	3 876 mm	4 486 mm
Weight, incl. drill	475 kg	495 kg	525 kg	540 kg
Feed force	15.0 kN	15.0 kN	15.0 kN	15.0 kN

### Boom

- Boom ..... BUT 28
- Feed extension ..... 1 250 mm
- Boom extension ..... 1 250 mm
- Parallel holding ..... complete
- Feed roll-over ..... 360°
- Max. lifting angle ..... +65°/-30°
- Max. swinging angle ..... +45°/-25°
- Weight, boom only ..... 1 750 kg

### Air system

- Electronically driven screw compressor ..... Atlas Copco LE7
- Capacity, max at 7 bar ..... 12.5 L/s
- Air pressure gauge

### Water system

- Electronically driven water booster pump .... Lowara 10SV13F055
- Water booster pump max capacity at 13.5 bar ..... 100 L/min
- Min water inlet pressure ..... 2 bar
- Water flow guard

### Control system

- Direct hydraulic Control System, DCS
- Basic functions such as anti-jamming included

### Drilling system

- Rock drill lubrication warning kit
- Big hole drilling system
- Mining (heavy duty) centralisers

### Electrical system

- Total installed power..... 125 kW
- Main motors power..... 2x55 kW

- Voltage ..... 380-1 000 V
- Frequency ..... 50-60 Hz
- Starting method ..... star/delta (1 000 V direct start)
- Thermal overload protection for electric motors
- Percussion hour meter
- Digital voltmeter/amperage meter in electric cabinet
- Phase sequence indicator
- Earth fault indicator
- Battery charger
- Transformer ..... 3.9 kVA
- Cable reel, (inner/outer diameter)..... 660/1 395 mm

### Hydraulic system

- Hydraulic pumps..... 2 separate units, one for each boom
- Pumps unloaded at start
- System pressure, max ..... 230 bar
- Hydraulic oil tank, volume max/min ..... 195 L
- Oil temperature gauge on oil tank
- Electrical oil filling pump
- Oil filter indicator
- Water cooled oil
- Filtration ..... 16 µm
- Mineral hydraulic oil
- Two operator control panels

### Carrier

- Deutz TCD3.6 L4, 4-cylinder water-cooled diesel engine, Chinese Stage III
- Power rating at 2 300 rpm ..... 55.4 kW (75 hp)
- Torque at 1 300 rpm ..... 390 Nm
- Articulated steering ..... ±41° steering angle
- Fixed seat, with safety belt
- Four-wheel drive
- Hydrostatic power steering system
- Hydrodynamic transmission ..... Clark 12 000
- Front axle ..... Dana 123
- Rear axle ..... Dana 123, ±6° oscillation
- Automatic differential lock on rear axle
- Tyres ..... Michelin 12.00xR20
- Clearance outside axles ..... 15"
- Hydraulic jacks, front ..... 2 extendable
- Hydraulic jacks, rear ..... 2
- Service brakes ..... 2 separate circuits
- Emergency and parking brakes ..... SAHR
- Fuel tank, volume ..... 60 L
- Silencer
- Electric system ..... 24 V
- Batteries ..... 2 x 70 Ah
- Trimming lights ..... LED 8x25W, 24 V DC
- Working lights ..... LED 4x50W, 24 V DC
- Adjustable fire extinguisher bracket
- Central lubrication system
- Spirit level
- Gradeability at max. load on drive wheels ..... 1:4
- Horn, beacon and reverse alarm

## Optional equipment

### Drifter rods

Dimension		Min. hole diameter
mm	T38-H35-R32	38
	R38-H32-R32	38
	R38-H35-R32	45

### Shank adapters

Thread		Diameter	Length
mm	R38	38	435
	T38	38	435
	T38*	38	525

\* Intended for extension drilling with BSH 100i.

### Rock drill/Drilling system

- Water mist flushing, external water and air supply
  - Hydraulic oil cooled by water
  - Hydraulic oil cooled by air fan
- Hole blowing kit without air receiver (for Canada)
- Hole Blowing Kit (internal system with CE certified air receiver)
- External air supply for hole blowing kit

### Feed

BMHT 2000 series	BMHT 2x37/22	BMHT 2x43/25 (heavy duty)
Total length	5 297/3 787	5 936/4 126
Drill rod length	3 700/2 200	4 310/2 500
Hole depth	3 388/1 888	3 883/2 057
Weight incl. rock drill	630kg	640kg
Feed force	15kN	15kN

- Extension drilling set BSH 110 (BMH feeds only)
- Clamp style hose tree on feed/s
- Rubber bushing type centralisers
- Dowel spacer for BMH 2000/6000 series feeds (not for BMHT and BSH110, only for rubber bushing type centralisers) (for Canada)
- Feed mount off-set kit (all boom/s) (for Canada)

### Couplings

Thread		Diameter	Length
mm	R38	55	170
	T38	55	190

### Boom

- Feed Angle Measurement system (FAM I)
- Feed Angle Measurement system with hole depth measurement (FAM II)
- Feed Angle Measurement system with hole depth and drill plan (FAM III)
- Automatic boom lubrication kit, rear part of boom

### Protective roof

- Manual spotlight, left and/or right
- Outlet for communication radio, 12V
- Illuminated stairs for platform

### Water system

- Water hose reel, including water hose

### Hydraulic system

- Hydraulic oil thermostat
- Heater kit for hydraulic oil tank

### Carrier

- Fire suppression system ANSUL (manual or Checkfire)
- Deutz D914 L04 2 V, 4-cylinder air-cooled diesel engine, 55 kW, EU stage IIIA / Tier 3
- Deutz BF4L 914, 4-cylinder air-cooled diesel engine, 72 kW, EU Stage II / Tier 2

### Electrical system

- Electric cable type Buflex
- Plug for cable
- Switch gear
- Socket
- Connector

### Miscellaneous

- Hydraulic Swellex pump type H1 for manual installation
- Manual lubrication kit
- Rig washing kit with water hose and reel
- Boots washing kit
- Ni-Cr plated piston rods (limitations exist)
- KA Certificate (Safety Certificate of Approval for Mining Products in China, selection on request)

## Measurements

### Side view

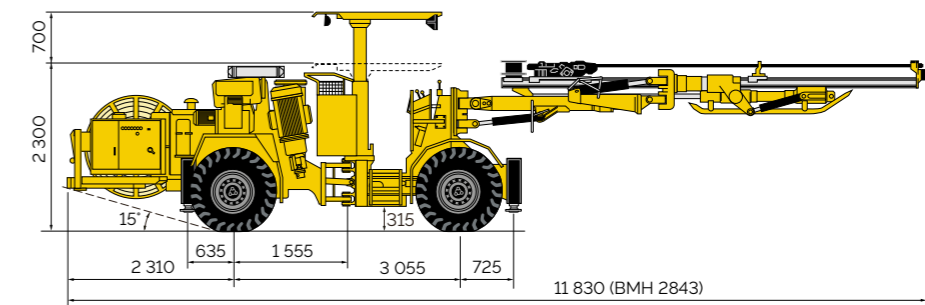

### Coverage area

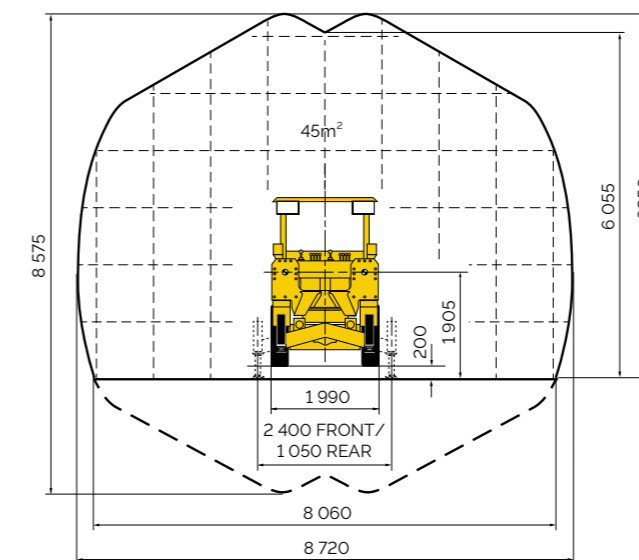

### Dimensions

mm		
	Width	1 990
	Height with cabin	3 050
	Height roof up/down	3 000/2 300
	Length with BMH 2343 feeds	11 830
	Ground clearance	315

### Weight

gross weight, depending on configuration		
kg	Total	18 300
	Boom side	12 800
	Engine side	5 500

### Turning radius

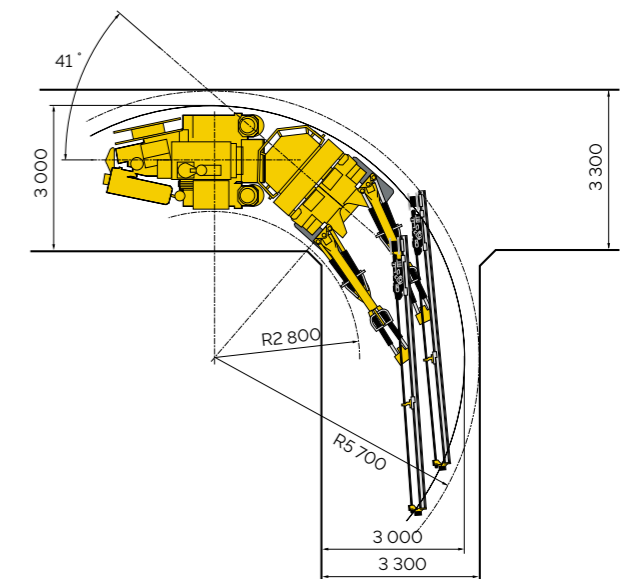

### Tramming speed

km/h	On flat ground (rolling resistance 0.05)	>12.5
------	--	-------

### Recommended cable size and length

Voltage	Type	Dimension, mm²	Diameter, mm	Length, m
380-550 V	Buflex	3x120+3G25+2x1.5	46	115
440-550 V	Buflex	3x95+3G16+2x1.5	45	120
575 V	Buflex	3x70+3G16+2x1.5	39	140
660-690 V	Buflex	3x50+3G10+2x1.5	33	140
1 000 V	Buflex	3x50+3G10+2x1.5	33	140

Recommendations are given for surrounding temperature of 40 °C and up to altitude of 2 000 m.



9869.0030.01a | 2020-07 | Nanjing, China Legal Notice © Copyright 2018, Epiroc (Nanjing) Construction Equipment Ltd. All product names in this publication are trademarks of Epiroc. Any unauthorized use or copying of the content or any part thereof is prohibited. All trademarks and photos may show equipment with different configurations. This warranty is made regarding specifications or otherwise. Specifications and equipment are subject to change without notice. Consult your Epiroc Customer Center for specific information.

# United in performance. Inspired by innovation.

Performance unites us, innovation inspires us, and commitment drives us to keep moving forward. Count on Epiroc to deliver the solutions you need to succeed today and the technology to lead tomorrow.  
**[epiroc.com](http://epiroc.com)**

