



Material Handling Solutions by **Omega Lift**



ALPHA Series



STANDARD EQUIPMENT

Engine

- Perkins diesel engine
- EPA compliant
- Glow Plugs

Transmission

- Power shift transmission—
3 speeds forward / 3 reverse
- Electric column shifter with torque converter
- Transmission disconnect on park brake
- Transmission oil cooler

Axles/Brakes

- Planetary 4-wheel drive
- 3 steering modes: 4WS/crab/2WS
- 4-wheel enclosed, wet disc brakes
- Oscillating rear axle
- Hydraulic powered brakes with accumulator
- Internal spring-applied hydraulic release park brake (SAHR)

Operator Compartment

- Open FOPS
- Tilttable and telescopic steering column
- Low profile mechanical suspension seat with lumbar adjustment and retractable seat belt

- Grab handles and cab step
- Roof glass

Instrumentation

- Full gauge cluster including; fuel level, water temperature, engine oil pressure, AMP meter.
- Indicator lights including; low battery, low oil pressure, high water temperature, high transmission oil temperature, glow plugs, park brake

Mast/Carriage

- I-beam roller mast
- Clear View design
- Premium mast chain
- Hardened chain pulleys
- Sealed, maintenance-free roller bearings
- Shaft Carriage
- Shaft Forks

Electrical

- 12 V negative ground system
- Labeled fuses with holder
- 970 CCA battery
- 65 AMP alternator

Additional Features

- Frame leveling
- Solid steel frame
- Steel hydraulic and fuel tanks
- Lockable fuel, hydraulic, engine hood and battery compartment
- Front work lights
- Rear flashers
- 2-stage air cleaner
- Horn and back-up alarm

OPTIONAL EQUIPMENT

- Enclosed all-weather cab
- Block heater with extension cord
- Air Conditioning
- AM/FM CD Sound System
- Lighting package
- Mirror package
- Washer system
- Foam-filled tires
- Customizable mast, carriage and forks
- Anti-theft device
- Fork Positioning
- Side shift
- Various Engine Options



1.905.857.6456 | www.omegalift.net

ALPHA Series

6,000 lbs load capacity

The muscular **ALPHA Series** is a solid rough terrain machine that provides the robust build quality of the larger Omega Lift models in a compact, efficient package. The exceptional maneuverability of this 4-wheel drive, 4-wheel steer machine ensures that it is perfectly suited for applications where space is limited.

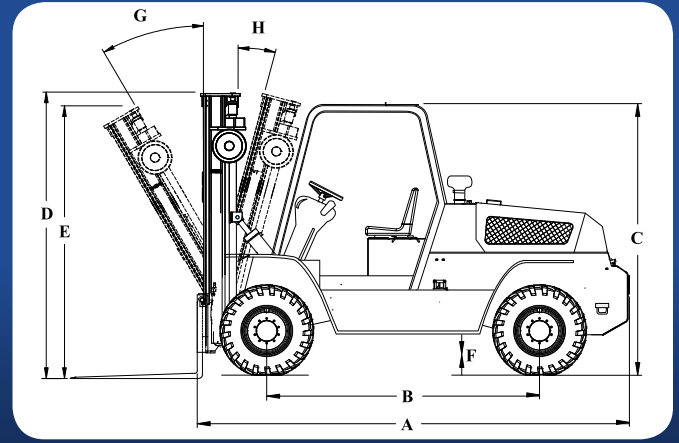

SPECIFICATION	Ref.	446-AS
Lift Capacity @ 24" load centre (lbs)		6,000
Overall length (without forks)	A	143"
Overall width		64"
Wheelbase	B	86"
Height to top of canopy	C	90"
Closed height standard mast	D	100"
Maximum lift height (std. mast)		120"
Height standard full mast tilt	E	98"
Outside turning radius		118"
Ground clearance	F	14"
Mast clearance		11"
Mast tilt - forward	G	25°
Mast tilt - rear	H	15°
Travel speed unladen - forward		13 mph
Gradeability		40%
Steering		4WS/Crab/2WS
Drive		4-wheel drive
Tire size - front		825-15 14G TT
Tire size - rear		825-15 14G TT
Engine Manufacturer and model		Perkins 1104 Natural Diesel
Cylinders		4 Cylinders
Horsepower		64 kW (86 HP) @ 2400 rpm
Transmission		Powershift—3 speed forward / 3 reverse
Shipping weight (lbs)		12,440

Manufacturers specifications subject to change without notice

NOTE: The information herein is general in nature and is not intended for specific application purposes. Omega Lift reserves the right to make any changes in the specifications shown herein, and improvements, or discontinue manufacture at any time without notice or obligation. Units shown may be equipped with non-standard equipment. All machines are manufactured to meet or exceed ANSI/ITSDF B56.6 - 2005 Standards or Recommended Practices, where applicable. Printed in Canada. Reorder Code: ALPHASS-I-10-11

